

Koheras BASIK

Low Noise Single Frequency Laser Module

PRODUCT GUIDE



Item:
Customer Revision:
NKTP Revision:
Release Date:

800-601-01
1.5
2.0
03-2022

PRODUCT GUIDE

This guide includes the following NKT Photonics Lasers:

Koheras **BASIK**

Low Noise Single Frequency Laser Module

GUIDE OVERVIEW

This product guide is intended to provide functional, operational and installation information for the Koheras BASIK laser modules. The guide is divided into three sections:

- **Koheras BASIK Description** - introduces the laser, its functionality, interfaces and chassis variants.
- **Operating the Laser** – provides information and procedures on how to connect, configure and manage the laser.
- **Installing the Laser** – includes the details on how to install the laser and connect optional interfaces.



Warning: Do not operate the laser before first reading and understanding all warnings, cautions and handling information stated within the document:

Koheras BASIK Safety, Handling and Regulatory Information



Note: The paper copy of this document is included with your laser however it can also be downloaded from:

<https://www.nktphotonics.com/lasers-fibers/support/product-manuals/>

Terminology This guide may refer to the Koheras BASIK modules as “the laser” or as “the module”. In specific cases where a distinction is required, this guide will use the actual laser model names.

Target audience This guide is for technical personnel involved in the selection, planning and deployment of lasers in laboratory and industrial settings. The guide assumes a reasonable knowledge level of lasers, photonic principles and electrical interface connectivity.

Chapters inside This guide includes the following chapters:

- Chapter 1 “**Laser Description**” — Describes the laser including its general operational principles, management and interfaces.
- Chapter 2 “**Modulation**” — Information on implementation of the laser’s wavelength modulation feature.
- Chapter 3 “**Communicating with the Laser**” — Provides information and procedures on how to setup a PC with the laser’s management software and connect it to the laser.
- Chapter 4 “**Turning ON the Laser**” — Contains procedures on how to safely enable and disable laser emission using the management software.

- Chapter 5 “Using CONTROL” — Includes descriptions of all NKT CONTROL menu, settings, and panel items.
- Chapter 6 “Software Development Kit” — Includes descriptions and procedures for some of the key settings that can be configured and monitored using the SDK’s Generic User Interface.
- Chapter 7 “Mechanical Installation” — Includes information and procedures on how to correctly install the laser chassis. Procedures within this chapter focus on providing adequate temperature regulation.
- Chapter 8 “Connecting the Laser” — This chapter provides information on how to physically connect the safety interlock, power, the optical connections, and the BASIK interface board.
- **Appendices** — The guide includes multiple appendices including laser specifications, support contact details, accessory descriptions, a configuration ID cross-reference and miscellaneous procedures and information supporting the laser operation and installation.

Added information and safety notices

Lasers are highly dangerous devices that can cause serious injury and property damage. This guide use the following symbols to either highlight important safety information or provide further information in relation to a specific topic.



Note: Highlights additional information related to the associated topic and/or provides links or the name of the NKT guides describing the additional information.



Caution: Alerts you to a potential hazard that could cause loss of data, or damage the system or equipment.



Warning: The laser safety warning alerts you to potential serious injury that may be caused when using the laser.

Revision This section records the document revision details.

Date	Revision	Changes
2019-10	1.0	First release - documents rewritten and overhauled from earlier releases.
2020-01	1.1	Added appendix F - Configuration IDs: configuration ID description and cross-reference for standard configuration IDs.
2020-06	1.2	Removed requirement to install a heat sink when operating under normal conditions. Replaced the warranty void label shown in appendix B.

Date	Revision	Changes
2021-01	1.3	Updated support contact information in appendix B.
2022-02	1.4	<p>Updates include minor grammar corrections and improvements in language clarity. Some figures have also been modified for clarity.</p> <ul style="list-style-type: none"> • Updated Table 20 on page 113. • Updated Procedure 9 on page 115 to Windows 10. • Added scales drop down selection description in Procedure 3 on page 56. • Added power scale drop down selection of wavelength or offset to section “Power mode” on page 76. • Updated description in section “Main adapter” on page 121. • Added interlock jumper to Figure 74 on page 122.
2022-03	1.5	<p>Updated with the following:</p> <ul style="list-style-type: none"> • Removed the misapplied serial monitor description and replaced it “Device Monitor” on page 77. • Updated Table 11 on page 79. • Updated “Setting the operating mode” on page 80. • Updated “Auto start” on page 80. • Updated “Narrow and wide range setting” on page 81. • Updated “Setting the wavelength modulation source” on page 82. • Updated “Setting the wavelength modulation signal coupling” on page 83. • Updated “Internal generator -signal output” on page 85.

CONTENTS

Guide Overview	3
Terminology	3
TABLES	13
FIGURES	15
PROCEDURES	19

Section 1	KOHERAS BASIK DESCRIPTION	21
1	Laser Description	23
	Features and options	23
	Theory of operation	24
	Module variants	24
	Configuration ID	24
	Center wavelength	24
	Output power	25
	Tuning types	25
	Front and rear panels	25
	Front panel	25
	Rear panel	26
	Optical specifications	27
	Laser features	27
	Thermal tuning	27
	Fast wavelength modulation	28
	External cavity stabilization	29
	Operating mode	29
	Trigger	29
	Auto-start	29
	Emission delay	30
	Shutdown delay	30

High temperature shutdown	30
Power verification	30
Miscellaneous	31
Power supply	31
Safety	31
Accessories	31
Optical interface.....	32
Optical fibers, connectors and adapters	32
Laser control	33
User interface	33
Status LEDs	33
Module labels	34
2 Modulation	37
Fast wavelength modulation	37
Configuring external and internal wavelength modulation	37
Wavelength+/- signal	38
Differential input	39
Single-ended to differential	39
Singled-ended input	39
Wavelength- to GND	41
Differential output	42
Wavelength modulation coupling	42
Narrow versus wide modulation range	42
Frequency response	42
External cavity stabilization (BASIK X15)	44
Setting up external cavity stabilization	45

Section 2	OPERATING THE LASER	47
3	Communicating with the Laser	49
	Connection kit	49
	CONTROL software	49

Installing the software	49
Software Development Kit	50
Generic User Interface	50
Connecting CONTROL to the laser	50
Connecting the SDK GUI to the laser	53
4 Turning ON the Laser	55
Safety	55
Preparation	55
Controlling the laser emissions	56
Turning On the laser	56
5 Using CONTROL	59
CONTROL overview	59
Relocating panels	60
Toggling panels visible	61
Connecting to the laser	61
.....	62
Device selector	62
Status panel.....	63
Status indicators	63
Module info	64
Measurements	64
WL mod button and indicator	64
Emission button	64
CONTROL settings.....	65
Wavelength modulation	65
Trigger	69
Power/Current mode	70
Auto-start	71
View	71
CONTROL menu items	72
Key Updater tool	72

Log Downloader	73
Extensions Overview	74
CONTROL – Control panel	75
Wavelength	75
Power mode	76
Current mode	76
Device Monitor.....	77
Application log	78
6 Software Development Kit	79
Read/write registers.....	80
Tuning the wavelength	80
Setting the operating mode	80
Auto start	80
Setting the emission delay	81
Narrow and wide range setting	81
Setting the wavelength modulation source	82
Setting the wavelength modulation signal coupling	83
Internal generator frequency	84
Internal generator amplitude	84
Internal generator signal waveform	84
Internal generator -signal output	85
Wavelength modulation on/off	86
Trigger setting input/output	86
Trigger indicates emission	87
Trigger sawtooth wavelength modulation	87
Readings	88
Errors and status indicators.....	89
Status indicators	89
Error codes	89
Graphing	89

Section 3	INSTALLING THE LASER	91
7	Mechanical Installation	93
	General	93
	Standalone mounting	93
	Heat dissipation	93
	Slide-in mounting.....	95
	Operating and storage environment	96
8	Connecting the Laser	97
	Connecting the safety interlock	97
	Interlock operation	97
	Lemo connector	97
	Connecting an interlock switch	98
	Connecting power.....	99
	Connecting modulation signals	99
	BASIK interface board	99
	Connecting the trigger input or output	102
	Input trigger	102
	Output trigger	103
	Connecting the optical output	103

Appendices

A	Specifications	107
B	Service and support Information	111
	Servicing the laser	111
	Opening the laser chassis	111
	WARRANTY VOID IF REMOVED Label	111
	Support contact details	112
	Support website	112
	Shipping address	112
C	Interface Pin Assignments	113

Main electrical interface	113
D CONTROL Software	115
Installing CONTROL	115
E RS-485 adapter	121
Main adapter	121
F Configuration ID	123
Module Configuration ID	123

TABLES

Table 1: BASIK variant specifications.....	24
Table 2: Recommended power modes.....	29
Table 3: Optical Interface Specifications	33
Table 4: Status LEDs.....	34
Table 5: Module labels	35
Table 6: Wavelength modulation settings.....	38
Table 7: Narrow vs wide band wavelength modulation	42
Table 8: Koheras BASIK PC connection kit.....	49
Table 9: CONTROL panels and menu items.....	59
Table 10: Device Monitor parameters	77
Table 11: Generic user interface registers	79
Table 12: Power adapter specifications.....	99
Table 13: Wavelength modulation pin descriptions	101
Table 14: Extra I/O pin descriptions	101
Table 15: Optical	107
Table 16: Mechanical dimensions	107
Table 17: Operating and storage environment	107
Table 18: Electrical.....	108
Table 19: Safety and regulatory compliances	108
Table 20: Main electrical interface pin assignment.....	113
Table 21: RS-485 adapter status LEDs.....	122
Table 22: Standard BASIK configuration IDs	123

FIGURES

Figure 1: BASIK front panel	23
Figure 2: BASIK front panel layout	26
Figure 3: BASIK rear panel layout	27
Figure 4: Frequency response using wavelength modulation	28
Figure 5: USB-RS485 Adapter	31
Figure 6: BASIK equipped with fiber cord and FC/APC connector	32
Figure 7: Status LEDs	33
Figure 8: Top panel label locations	34
Figure 9: Front panel label locations	35
Figure 10: Differential input signal for wavelength modulation	39
Figure 11: Single-ended to differential	39
Figure 12: Single-ended input signal with 2.5 V	40
Figure 13: Single-ended input with 2.5 V on an unused branch	40
Figure 14: Single-ended input signal with GND on an unused branch	41
Figure 15: Single-ended input connections with 0 V on an unused branch	41
Figure 16: Differential output signal	42
Figure 17: BASIK X15 wavelength modulation response	43
Figure 18: BASIK E15/C15/Y10 wavelength modulation response	44
Figure 19: BASIK X15 in Pound-Drever-Hall configuration	44
Figure 20: GUI panel navigation	59
Figure 21: Relocating panels within CONTROL	60
Figure 22: Dragging panels outside the main window	60
Figure 23: Toggling panel visibility	61
Figure 24: Welcome screen and connecting	61
Figure 25: Connect button	62
Figure 26: Device selector panel	62
Figure 27: Status panel	63
Figure 28: GUI settings	65

Figure 29: Wavelength modulation - internal source	66
Figure 30: Wavelength modulation - external source	66
Figure 31: Wavelength modulation - both	67
Figure 32: Internal generator waveform selection – Type setting	67
Figure 33: Turning on wavelength modulation	69
Figure 34: Trigger type – Input	70
Figure 35: Trigger type – Output	70
Figure 36: Power and current mode controls	71
Figure 37: Auto-start setting	71
Figure 38: View setting	71
Figure 39: Menu items	72
Figure 40: Extensions Overview	75
Figure 41: Wavelength controls	76
Figure 42: Operating mode set to power	76
Figure 43: Serial Monitor	78
Figure 44: Setting the wavelength offset	80
Figure 45: Setting the operating mode	80
Figure 46: Setting the Auto-start function	81
Figure 47: Setting the emission delay	81
Figure 48: Setting the modulation range parameter	82
Figure 49: Setting the wavelength modulation signal source	82
Figure 50: Setting the coupling type	83
Figure 51: Setting the internal generator frequency	84
Figure 52: Setting the signal amplitude of the internal generator	84
Figure 53: Setting the internal generator waveform	85
Figure 54: Toggling the internal generator signal output	85
Figure 55: Turning ON wavelength modulation	86
Figure 56: Setting the trigger to input or output	86
Figure 57: Trigger set to indicate emission	87
Figure 58: Trigger set to sawtooth wavelength modulation	87
Figure 59: Read-only registers under the Readings tab	88

Figure 60: Error and status tab	89
Figure 61: Graphing tab	90
Figure 62: Heat transfer surface - BASIK rear panel	93
Figure 63: Heat transfer surface - BASIK rear panel	94
Figure 64: Mounting the laser	95
Figure 65: Front panel mounting holes and handle	96
Figure 66: Safety interlock connected to a door switch (open position)	98
Figure 67: Power supply	99
Figure 68: BASIK interface board	100
Figure 69: Trigger input circuit	102
Figure 70: Trigger output circuit	103
Figure 71: Mechanical dimensions	109
Figure 72: Warranty seal	111
Figure 73: Main electrical interface PIN layoutl	113
Figure 74: RS-485 adapter	122
Figure 75: How to read the configuration ID	123

PROCEDURES

Procedure 1: Connecting CONTROL to the laser	51
Procedure 2: Connecting the SDK Generic User Interface to the laser	53
Procedure 3: Turning on the laser using CONTROL	56
Procedure 4: Turning on the laser using the Generic User Interface	58
Procedure 5: Relocating panels	60
Procedure 6: Using the Key Updater tool	72
Procedure 7: Using the Log Downloader.....	73
Procedure 8: Connecting the door interlock circuit (with the RS-485 adapter) 98	
Procedure 9: Installing CONTROL	115

SECTION 1

KOHERAS BASIK DESCRIPTION

This section provides a description of the laser and its chassis types. It includes the following topics:

- “Laser Description” on page 23
- “Module variants” on page 24
- “Main electrical Interface” on page 26
- “Laser features” on page 27
- “Miscellaneous” on page 31
- “Optical interface” on page 32
- “Laser control” on page 33
- “Status LEDs” on page 33
- “Module labels” on page 34

1 Laser Description

Koheras BASIK is a single frequency distributed feedback (DFB) fiber laser system housed in a robust package with passive vibration reduction. The laser is available as single laser or as a building block used for example, in multi channel DWDM systems. The laser features an ultra-narrow line width that falls in the Hertz range with exceptionally low frequency and low intensity noise.

Applications for the laser include quantum computing, coherent sensor applications (in oil and gas exploration), perimeter and submarine detection systems, wind LIDAR, and coherent optical communications. The BASIK is also ideal as the base seed laser for a larger laser system as is the case with the Koheras ADJUSTIK HP system where it operates as the seed. The laser's special modular case design allows it to be used both as a stand-alone system or as a plug-in module inserted in a multi-channel laser system such as the Koheras ACOUSTIK for applications requiring multiple light source channels.

Figure 1 BASIK front panel

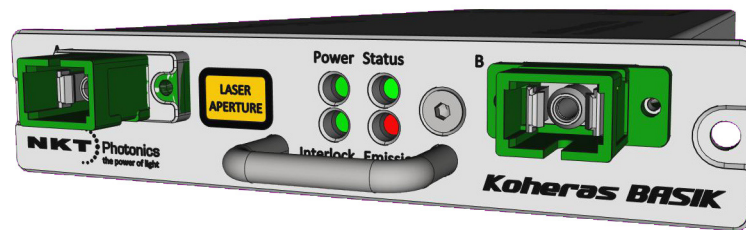

Four variants of the BASIK are available with additional options that can be specified. The variants are all designed with distributed feedback fiber laser technology and center wavelengths which can be specified from either 1535 to 1580 nanometers or 1030 to 1120 nanometers. All variants also supports a wide tuning range of approximately 1 nm from the specified center wavelength.

Features and options

The laser series includes the following features and options:

- *Thermal Tuning* – This can vary the wavelength through coarse thermal control of the laser substrate.
- *Piezo Tuning* – Provides fast wavelength modulation with finer control
- *Standard or Polarization Maintaining (PM) fiber* – PM fiber is available if the application requires that the polarization is preserved.
- *Wavelength modulation* – The wavelength is modulated using either an external or internal signal.
- *Power or Current modes* – The lasers operate in either constant power or constant current mode.

- *Emission features* – Multiple features that control emission availability from the laser.

Tuning is accomplished by either manual thermal tuning or using an external signal applied at the laser's fast wavelength modulation input port. A varying external signal applied to the port, modulates the output wavelength. Modulating the output wavelength improves stabilization when compared with the free-running wavelength specification.

The standard output of the laser utilizes either standard single mode fiber or optional polarization-maintaining fiber to improve the linear characteristics. Improved polarization linearity is usually required when the laser output is either externally modulated or frequency converted.

Theory of operation The BASIK is a fiber laser that uses a fiber Bragg grating cavity to produce an output beam operating in single mode. The center wavelength of the laser is configurable using either thermal substrate control or optional Piezo components. Due to the special Bragg grating, the single mode operation is constantly maintained and is stable over the entire operating frequency band of the laser.

Module variants

The Koheras BASIK modules are available in four variants. The modules are primarily classified by their wavelength and output power. [Table 1](#) describes the key technical differences between the variants.

Table 1 BASIK variant specifications

Module Type	Standard λ	Other λ s ¹	Output Power	Polarization Maintaining	Fast Modulation
X15	1550.12	1535 - 1580 nm	30 mW (fixed) ²	Yes	Yes
E15	1550.12	1535 - 1580 nm	40 mW (max.) ³	Optional	Optional
C15	1550.12	1535 - 1580 nm	>10 mW (fixed) ²	Optional	Optional
Y10	1064.00	1030 - 1120 nm	>10 mW (fixed) ²	Yes	Optional

1. Fixed
2. Actual value depends on the factory calibration
3. Min. output ~30% of the maximum

Configuration ID Koheras modules are defined by their configuration ID which includes the options. Refer to [Appendix F](#) for a list of Koheras BASIK configuration IDs.

Center wavelength The center wavelength of BASIK lasers is set to 1550.12¹ nm or 1064.00 nm. However, the lasers can be specially ordered from the factory with other center wavelengths ranging from 1535 to 1580 nm or 1030 to 1120 nm.

1. ITU DWDM C-BAND Channel 34

Output power The output power is fixed for each module type. However, depending on the module type, the set output power ranges from greater than 10 mW and up to and including 40 mW – see [Table 1](#).

Tuning types The laser’s variants can also be specified with different tuning options. Options include narrow and wide thermal tuning for coarse adjustment and Piezo tuning for finer adjustment. Tuning options are specified when the laser is ordered from the factory.

Thermal tuning

Thermal tuning options available are:

- *Narrow thermal tuning* – Provides narrow thermal tuning suitable for systems where a wide tuning range is not required but vibration immunity is vital.
- *Wide thermal tuning* – Provides a wider thermal tuning range at the expense of reduced immunity to vibration and acoustic pickup.

Piezo tuning

If the Piezo tuning option is included, the laser supports fine fast wavelength modulation. For further information see [“Fast wavelength modulation” on page 28](#)).

Front and rear panels

Front panel The front panel shown in [Figure 2](#) includes optical output fiber connectors and status LEDs. The laser has two optical outputs A and B. The outputs are assigned at the factory as either the main output, monitor output or blank. See [“Optical specifications” on page 27](#) for more information on the optical outputs and their connector configuration.

Status LEDs on the front panel indicate the following states:

- Power – the supply voltage status
- Interlock – interlock circuit open/closed (not OK/OK)
- Emission – the laser emission status
- Status – the module stability status

For more information see [“Status LEDs”](#) on page 33.

Figure 2 BASIK front panel layout

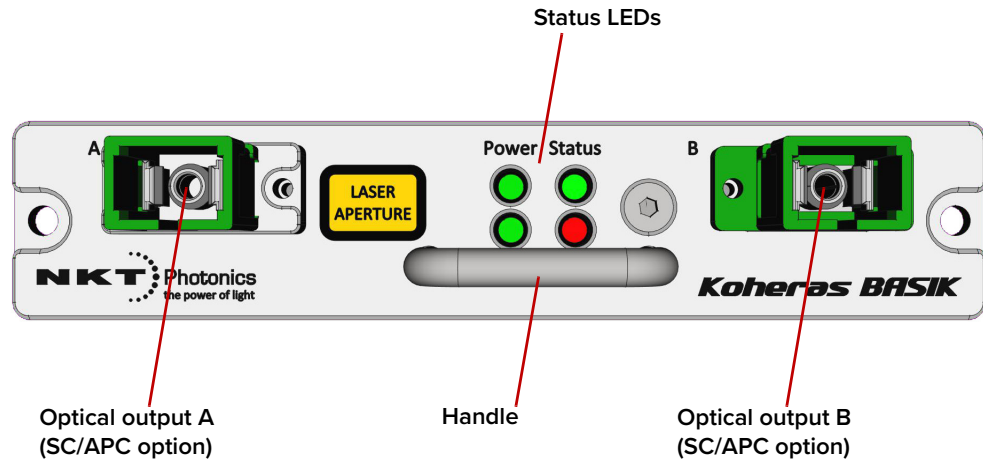

A BASIK includes a handle mounted underneath the status LEDs on the front panel. Use the handle for pulling the laser out from a slot mount (such as the Koheras ACOUSTIC). The front panel also includes two screw holes designed to fasten the laser securely in place when inserted in the slot of an ACOUSTIC or other custom installation.

Rear panel The rear panel, shown in [Figure 3](#), includes the main electrical interface, an alignment hole and two M4 tapped holes for fastening the laser from the rear.

Main electrical Interface

The main electrical interface is a DIN 30 pin C/3 type connector that provides all signal and power connections to the laser. Signals on the interface include:

- *Serial communication* – RS-485 communication signals.
- *Interlock* – Pins supporting a safety interlock circuit.
- *Emission control* – Gate signaling control of emission.
- *Modulation input/output* – Input signal to support wavelength modulation.

For all pin assignments of the connector, see [“Main electrical interface”](#) on page 113.

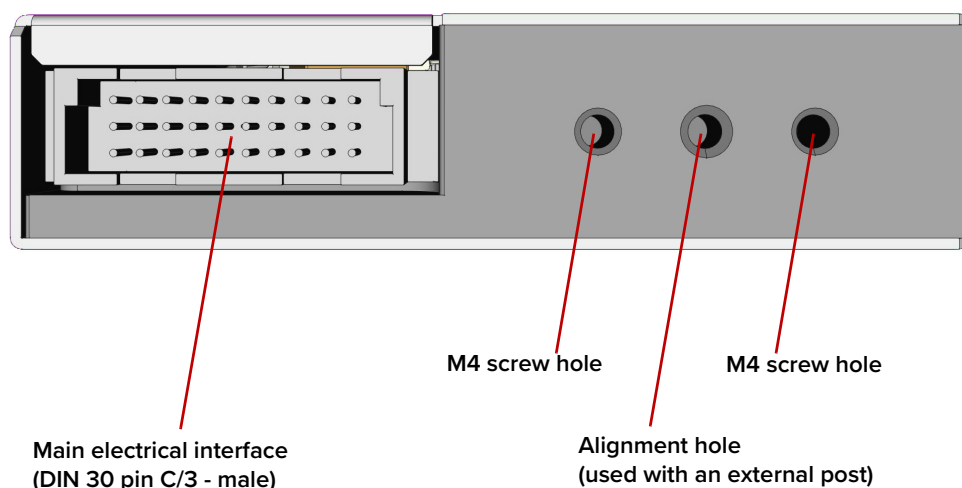
Figure 3 BASIK rear panel layout**Alignment and tapped holes**

If the laser is inserted into a slotted housing, the alignment hole of the module's rear panel is designed to slide onto an alignment post fixed to the housing. The post aids electrical connector alignment when the laser is pushed into a mount (slot, shelf, etc.). The laser is also supported by the post, relieving mechanical stress from the mated electrical connectors.

Two M4 tapped mounting holes can be used where it is advantageous to fasten and support the laser from the rear panel. For further information on installing the laser, see [“Mechanical Installation” on page 93](#).

[Figure 71 of Appendix A](#) shows the dimensions of the laser including the alignment and screw holes positions.

Optical specifications**Main optical output**

Laser emission from the output is classified as CLASS 3B. The main output is identified by the laser aperture label next to it.

Monitor Output

Emission from the optional monitor output is classified as CLASS 1 and therefore does not require a laser aperture label.

Laser features

Thermal tuning The wavelength of the laser is controlled using a thermal tuning technique that changes the temperature of the laser's fiber. The fiber laser is mounted under tension on a substrate. When the temperature of the substrate changes, the laser cavity length also changes due to thermal contraction or expansion. Further, the

temperature of the laser cavity itself also changes such that the laser wavelength changes in response to both thermo-optic and physical changes in the optical path length. See [“Tuning the wavelength” on page 80](#).

Fast wavelength modulation As an option, the laser includes the capability to use an external signal to modulate the emission wavelength using a Piezo. Laser modules with this option can be modulated using an external electrical signal.

Input circuits

Section [“Fast wavelength modulation” on page 37](#) provides examples of fast wavelength modulation circuits and performance.

Wavelength+/- Signal

To modulate the wavelength, apply an external differential signal to Pins A10 and C10 of the main electrical interface. See [“Main electrical interface” on page 113](#) for the connector’s pin assignment.

As this signal varies and increases its positive potential, the wavelength increases. [Figure 4](#) shows the frequency response when the fast wavelength modulation feature is utilized. The graph shows the response for both standard and wide thermal tuning substrates.

Figure 4 Frequency response using wavelength modulation

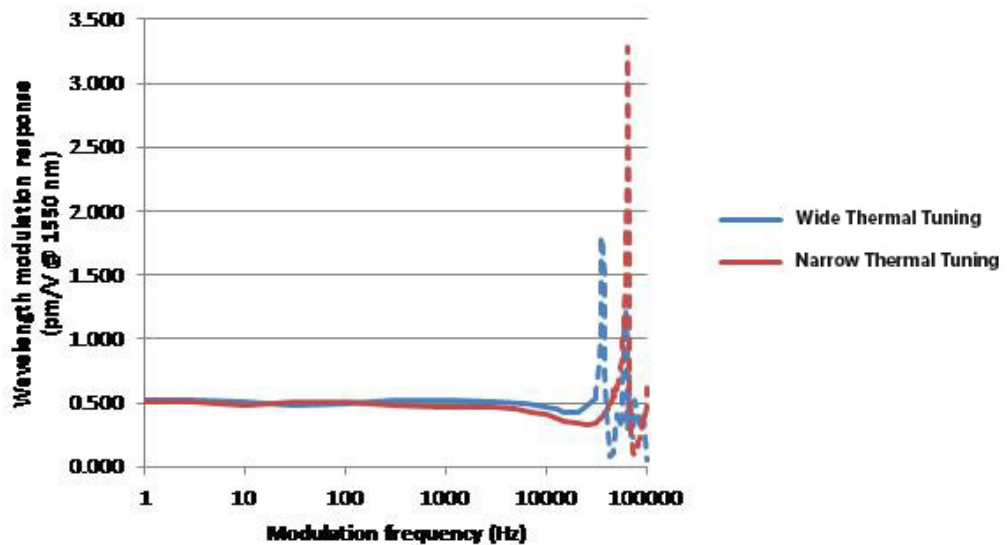

The response shown in [Figure 4](#) is for a laser with a wavelength at 1550 nm. The response is scaled linearly with the wavelength of the laser. Further, the Narrow Thermal Tuning module which has less vibration sensitivity, shows resonances that are higher in frequency. These modules are therefore more suitable for applications where modulations between 30 and 45 kHz are required.



Note: The frequency response is relatively flat up to 20 kHz, but resonances are seen at frequencies at and above the first resonance occurring at approximately 30 kHz. Wavelength modulation can be used for frequencies above 20 kHz, but it is recommended to avoid modulating the laser at the resonance frequencies.

External cavity stabilization X15 modules support the use of the Pound-Hall-Drever technique to reduce low frequency phase noise to an ultra-low level. It requires that the X15 output is stabilized using an external cavity circuit. Refer to [“External cavity stabilization \(BASIK X15\)” on page 44](#) for details of the implementation.

Operating mode All modules can operate in current mode, where the current in the pump feeding the fiber laser is kept stable. Some variants can operate in power mode as well, where the power out of the fiber laser is kept fixed.

- *Current mode* – The current in the pump feeding the fiber laser is held stable.
- *Power mode* – The optical output power of the fiber laser is held at a fixed level.

The mode set depends on both the model and the application, refer to [Table 2](#) for the recommended mode to use. See [“Setting the operating mode” on page 80](#).

Table 2 Recommended power modes

BASIK model	Power mode	Current mode
C15 & Y10	Better power stability	Better frequency stability
E15 & X15	Better performance	Not recommended



Note: Modules that support both modes are configured from the factory to operate in power mode.

Trigger A trigger logic input or output pin (see [Table 20](#)) is available on the electrical interface. The trigger pins can be used for two purposes:

- To input a logic high signal that initiates laser emission.
- To output a logic high signal that indicates laser emission.

For more information on connecting the trigger see [“Connecting the trigger input or output” on page 102](#).

Auto-start The laser includes an *Auto-start* control bit, when the bit is set, laser emission is enabled immediately after power is connected. This mode can be useful for applications where no communication with the module is possible. To enable the Auto-start function, see [“Auto-start” on page 71](#) and [“Auto start” on page 80](#).

Interlock

To enable emission using *Auto-start*, ensure the interlock signal in the electrical interface is set high before or the instant the module is powered up.



Note: *Auto-start* will not enable emission if after power-up, the interlock signal subsequently changes to high.

Koheras ADJUSTIK & ACOUSTIK

If the module is used within either an ADJUSTIK or ACOUSTIK chassis, *Auto-start* is overruled and cannot enable emission even if the *Auto-start* bit is set.

KeyUpdater

To enable/disable the *Auto-Start* feature, use the *KeyUpdater* tool in CONTROL with either key below.

- **Enable key – enables the Auto-start feature**

Q1PTF-9PCA1-9TF9P-723J9-9E9QV-V8999-99999-9E999-99999-9999N-IPUB6

- **Disable key – disables the Auto-start feature**

E0TDG-FT190-FDGFT-N6O3F-FAF0K-KZFFF-FFFFF-FFFFF-FFFFF-FFFFO-G6BF9

Emission delay The laser has an *Emission Delay* register which is set to 1.5 seconds by default. The moment emission is enabled, the emission LED on the front of the module and the emission output pin of the electrical interface immediately indicate emission. However with this feature, the actual emission of laser light is delayed by the time set with the register. See [“Setting the emission delay” on page 81](#).

Shutdown delay This feature delays disabling laser emission by 100 ms after the interlock/enable pins (See [“Main electrical Interface” on page 26](#)) are set to low or a disable command is sent. When the laser is integrated with an amplified system, the shutdown delay ensures the laser’s seed signal does not disappear before an interfacing amplifier is turned off.

High temperature shutdown To prevent thermal run-away when the laser module temperature exceeds 65 °C, this feature automatically shuts down (disables) emission. The feature uses the thermal control function inside the laser to shut down emission.



Note: The laser remains ON and has communications enabled, only emission is disabled by the feature.

Auto-Start

If, after the high temperature shutdown feature disables emission, the module temperature subsequently drops below 60 °C, emission is automatically re-initiated. This only occurs when laser emission was originally enabled before the high temperature shutdown and *Auto-start* features are enabled.

Power verification This feature internally monitors the output power level from the fiber stage. If power drops below a predefined level in relation to the measured pump current, laser emission is automatically disabled.



Note: The slope is different for each individual laser as their emission efficiency varies.

The feature prevents for example, the output power reaching its maximum value or emission continuing if feedback disappears (unexpectedly) to the internal output power control function.

Miscellaneous

Power supply The laser requires an external 12 VDC power source which is not included with the laser. Power is connected through the main electrical interface connector, see “Main electrical Interface” on page 26.



The NKT Photonics RS-485 adapter kit includes a power supply for the laser. See “Accessories” – “USB-RS485 adapter kit”.

Safety



Warning: The lasers are rated as class 3B lasers and are therefore hazardous. Before turning on the laser, ensure to read and understand all safety statements of the document:

Koheras BASIK Safety, Handling and Regulatory Information

A paper copy of this document is included with your laser. If you do not have access it, you can download a copy from:

<https://www.nktphotonics.com/lasers-fibers/support/product-manuals/>

Accessories USB-RS485 adapter kit

During integration testing or otherwise, an RS-485 adapter kit is available to connect a PC to the laser module. With the adapter, a PC or other micro-controller can be connected to the laser using a standard USB serial port. The kit includes a 12 VDC power supply, a 16 pin IDC to DB-15 connectorized ribbon cable, a type A to type B USB cable, and an interlock jumper. For more information about the adapter refer to Appendix E and “Connecting CONTROL to the laser” on page 50.

Figure 5 USB-RS485 Adapter



Optical interface

The laser has either one or two optical outputs (marked with an 'A' and a 'B' on the front of the module). Assignment of the output type depends on the laser configuration ordered from the factory. The optical outputs are assigned as either:

- **Main** – this is the laser's primary optical output (typically Class 3B) near which, a laser aperture label is affixed.
- **Monitor** – this is a low power output intended for monitoring purpose only. The output is classified as a laser CLASS 1 and therefore it does not require a laser aperture label.
- **Blank** – if no output is assigned to either A or B outputs, a blank panel is placed over the output.

Contact NKTP support for information on how the laser's optical ports are assigned. See ["Support contact details"](#) on page 112.

Optical fibers, connectors and adapters

If an optical output is assigned to port A or B, it can be configured with either:

- fiber patch cords with FC/APC connectors (FC/APC pig-tail)
- or –
- connector adapters (FC/APC adapter or SC/APC adapter)

[Figure 6](#) shows a Koheras BASIK assigned with a fiber patch cable and FC/APC connector assigned to optical port A as the main output. [Figure 2](#), shows the front panel layout when both optical ports are assigned as SC/APC adapters.

Figure 6 BASIK equipped with fiber cord and FC/APC connector

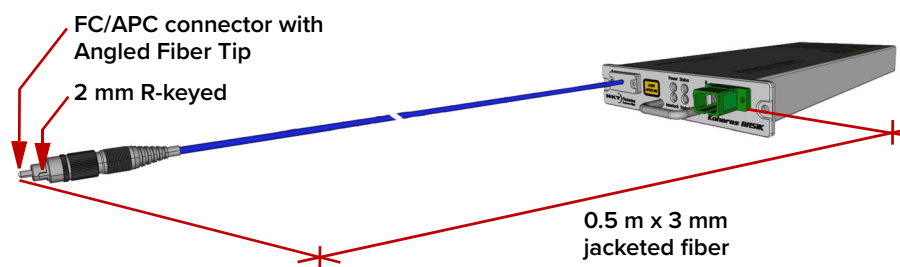

Polarization Maintaining Output (Panda PM 1550)

If the module includes an optional Panda polarization maintaining fiber cord, the slow axis is by default aligned to the connector key. Because of this, the laser polarization (E-field) is parallel to the key.

Table 3 Optical Interface Specifications

Parameter	SMF28	PM 1550
Fiber Mode Field Diameter ¹	~10 microns	~10 microns
Numerical Aperture	0.14	0.125

1. Mode field diameter is approximate - contact NKT Photonics Support for more information ([Support contact details on page 112](#)).

Laser control

User interface The laser and any associated accessories are controlled using either NKT Photonics CONTROL Graphical User Interface (GUI) installed on a PC or through the NKTP Software Development kit (SDK).

If you are using the SDK GUI, it can control the laser's emissions and adjust its power and wavelength settings. Multiple laser statuses, warnings, errors and parameters can also be viewed. Using the SDK kit to control the laser requires either integrating it with a custom control application or for testing purposes, the included Labview software.

The platform chosen, either PC or custom microprocessor, must connect over the laser's RS-485 serial interface (see "[Main electrical Interface](#)" on page 26).

[Section 2](#) includes multiple chapters describing the GUI and procedures related to controlling the laser with it.



Note: An optional USB to RS-485 adapter is available to connect a standard PC to the laser.

Status LEDs

The front panel houses four status LEDs as described in [Table 4](#). The LEDs are located on the front panel as shown in [Figure 7](#).

Figure 7 Status LEDs

Table 4 Status LEDs

LED Name	Condition	Description
Power	ON Green	DC Voltage at the DC power input pins is OK.
	ON Red	DC voltage at the DC power input pins is too low.
	Flashing Amber	The module is transmitting data.
	Off	No DC power at the module power input pins.
Emission	ON Red	Laser emission is ON.
	Off	Laser emission is OFF.
Status	ON Green	The module laser frequency is stable.
	ON Amber	Module enable low OR module not stable (frequency tuning)
Interlock	ON Green	The interlock status is OK – the door circuit is closed and energized.
	On Red	The interlock status is Not OK – the door circuit is open or not energized.

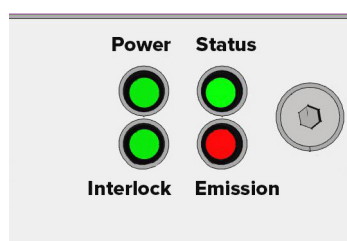

Note: DO NOT OPERATE the laser until you are familiar with the controls and have taken all precautions necessary as described in the document: *Koheras BASIK Safety, Handling and Regulatory Information*.

Module labels

The Koheras BASIK modules include multiple labels that indicate hazards, regulatory, or manufacturing information. The labels are located on the panels shown in [Figure 8](#) and [Figure 9](#) and described in [Table 5](#).

Figure 8 Top panel label locations

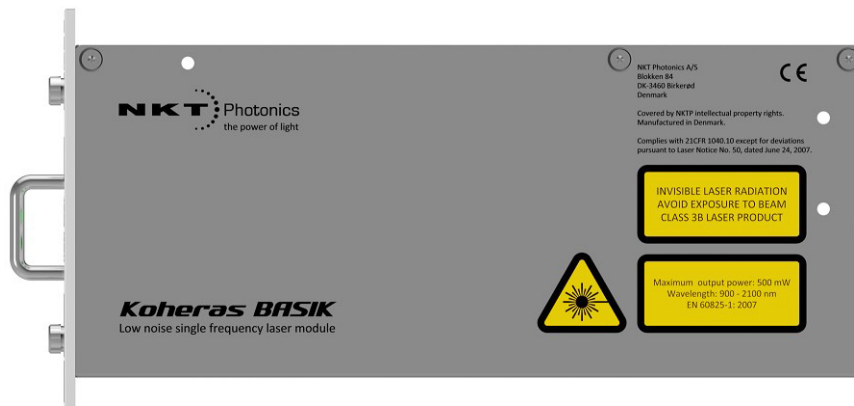

Figure 9 Front panel label locations

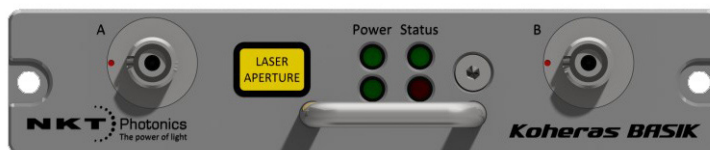

Table 5 Module labels

Label	Panel	Description	
Classification - Emission Hazards	Top	Safety information stating the laser emission hazards and the laser's class rating.	
Manufacturing	Side	Manufacturing information including address, part and serial number, date manufactured and regulatory compliance.	
Product Information	Top	Safety label showing the emission specifications the laser is capable of.	
Laser Radiation Warning	Top	Safety information alert indicating this area of the laser is near a source of dangerous laser emissions.	
Laser Aperture	Front	Safety information alert indicating the location of the aperture where laser radiation is emitted from the laser. If the module includes a monitor output, this is a class 1 laser output and does not require a label.	

2 Modulation

This section presents further information on how to implement:

- Wavelength modulation (fast) – “Fast wavelength modulation” on page 37
- External cavity stabilization – “External cavity stabilization (BASIK X15)” on page 44



Note: The wavelength modulation option must be specified when ordering the laser.



Note: E15 modules are able to decrease output power down to 30% of the nominal level. However, the laser’s performance varies depending on the level of the output power set. Therefore the E15’s performance is only guaranteed at the nominal (maximum) output power setting.

Fast wavelength modulation

If the fast wavelength modulation option is included with the laser, the output wavelength can be modulated by: connecting an external varying electrical signal, the laser’s internal function generator, or both.

Configuring external and internal wavelength modulation

As stated above, you can use the option to modulate the wavelength of the Koheras BASIK module with either:

- an external electrical signal applied to the *Wavelength+/-* input,
- the laser’s internal function generator
- or both

The firmware in the module is designed so at least one of the two modulation methods is enabled. Table 6 provides a description with cross-references of the settings involved when using fast wavelength modulation.

Table 6 Wavelength modulation settings

Setting	Function	For CONTROL see	For SDK see
External wavelength modulation	Sets wavelength modulation to external signal mode.	page 65	page 82
Internal function generator	Sets wavelength modulation to internal function generator mode.	page 67	page 82
Modulation frequency	Sets the frequency of the internal function generator. The settable range is from 0.008 Hz to 100 kHz.	page 68	page 84
Modulation amplitude	Sets the modulation maximum amplitude to between 0 & 100% when using the internal function generator mode.	page 68	page 84
Waveform	When set to internal function generator mode, waveform sets the signal type to either sinusoidal or sawtooth.	page 67	page 84
Signal output	Sets the wavelength+/- pins to output the internal function generator signal.	page 68	page 85
Wavelength modulation	Toggles all wavelength modulation functionality and settings on or off.	page 68	page 86

Wavelength+/- signal The *Wavelength+/-* pins (of the main electrical interface) are a differential input/output used for wavelength modulation of the laser – for pin descriptions, see [Table 20](#). You can configure the wavelength modulation option so that the interface is used either as input or output. It is preferential to use a differential signal for the modulating signal applied. When using a differential signal the combined voltage of the *Wavelength+* and *Wavelength-* pins modifies the wavelength with the following results:

- a negative voltage results in an output with a shorter wavelength.
- a positive voltage results in an output with a longer wavelength.

Differential input When configured as an input, the *Wavelength+/-* interface can be connected to a differential signal with an amplitude of up to 2×5 Vpp as shown in Figure 10.

Figure 10 Differential input signal for wavelength modulation

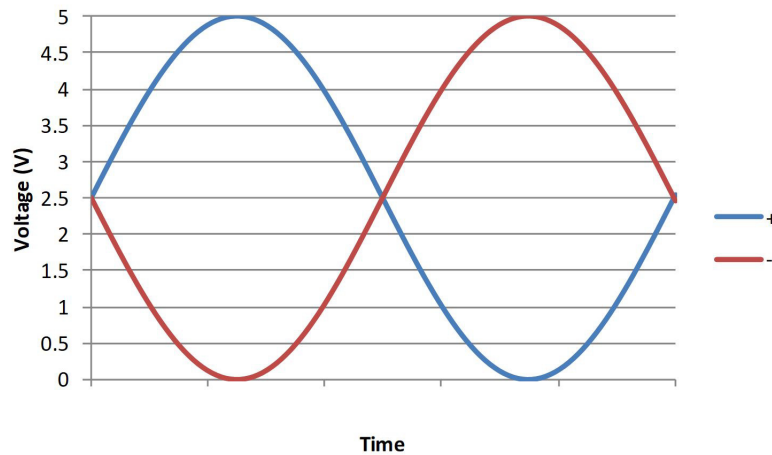

Note: To prevent noise being induced that could create undesired phase noise, it is recommended to disable the wavelength modulation setting when it is not in use.

Single-ended to differential The circuit shown in Figure 11 is an example of how to generate a differential signal from a single-ended input. In this example, a 5 Vpp single-ended input signal with a 0 V common-mode voltage generates a 2×5 Vpp differential signal with a 2.5 V common mode voltage.

Figure 11 Single-ended to differential

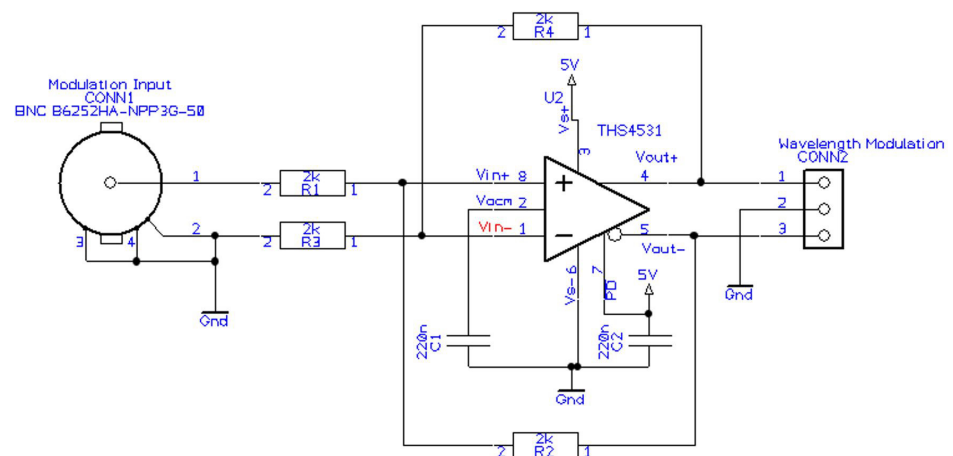

Singled-ended input If a differential signal is not available, a single-ended signal as shown in Figure 12 can be applied to the *Wavelength+* input. In this case, connect *Wavelength-* to

2.5 V or GND. A single-ended 5 Vpp signal generates half the modulation compared to a differential 2x5 Vpp input.

Figure 12 Single-ended input signal with 2.5 V

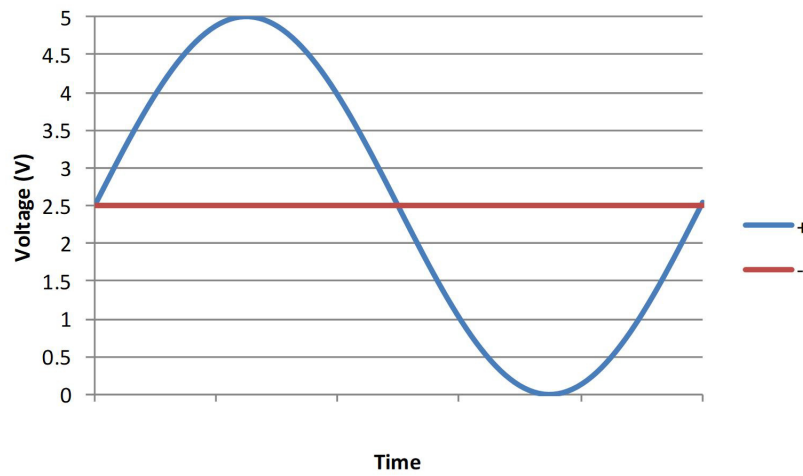
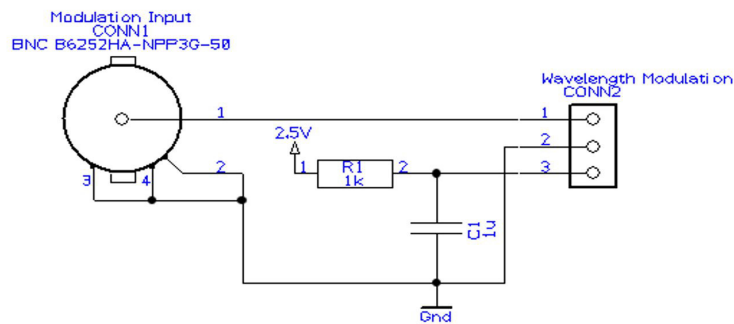

Figure 13 shows the *Wavelength-* pin connected to the same potential as the common mode voltage of the *Wavelength+* signal, the optical output will be modulated around its center wavelength.

Figure 13 Single-ended input with 2.5 V on an unused branch



Wavelength- to GND In **Figure 15**, the *Wavelength-* signal is connected to GND and the *Wavelength+* signal is modulated between 0 and 5 V as shown in **Figure 14**, the optical output is modulated above its thermally controlled wavelength.

Figure 14 Single-ended input signal with GND on an unused branch

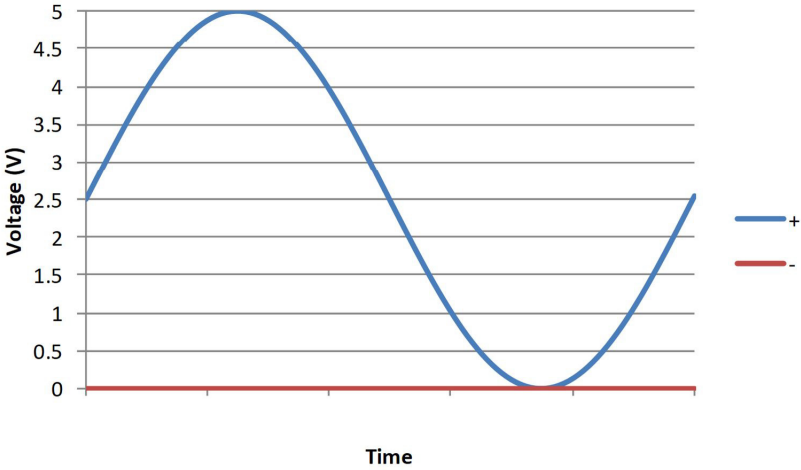
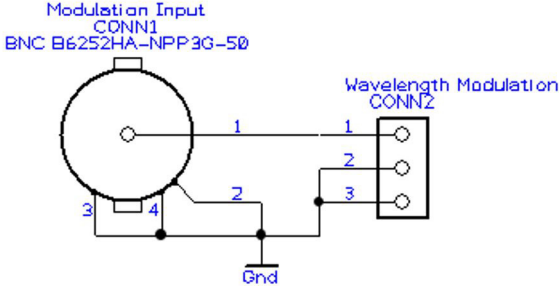
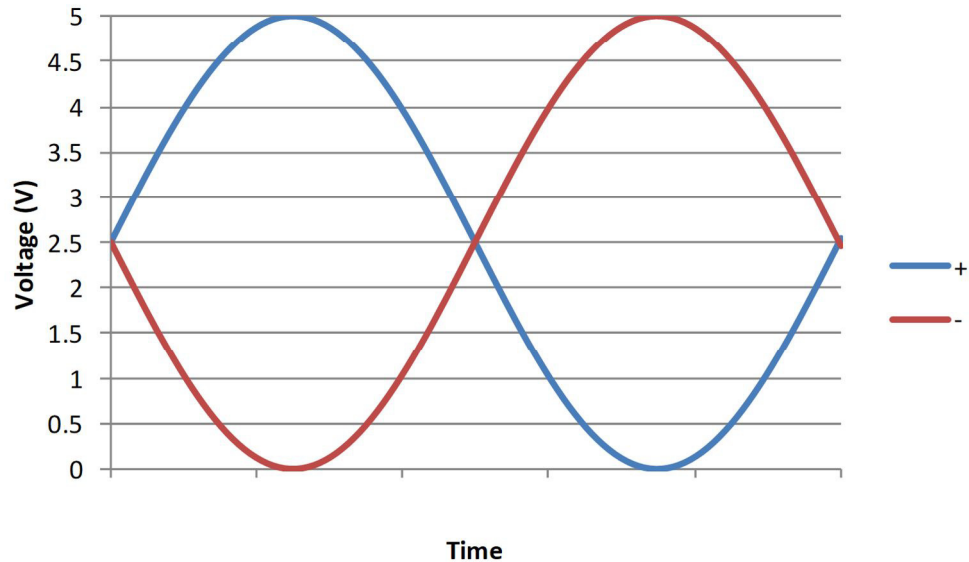

Figure 15 Single-ended input connections with 0 V on an unused branch



Differential output If the *Wavelength+/-* pins are configured as an output, a differential signal will be present at the pins as shown in [Figure 16](#). The differential signal amplitude can be up to 2×5 Vpp with a common mode voltage of 2.5 V.

Figure 16 Differential output signal



The differential output signal can be used for example, as the input signal for other Koheras BASIK modules.

Wavelength modulation coupling You can select either internal AC or DC coupling of the modulation signal. If AC coupling is chosen, the module's high pass filter function has a cut-off frequency of 1.6 Hz. Setting the Koheras BASIK X15 to DC coupling allows the laser to lock to an external reference signal that for example, uses the Pound Drever Hall technique. In this mode, the module adjusts its wavelength so the differential error signal level on the *Wavelength+/-* input leans towards 0 V.

Narrow versus wide modulation range You can set the wavelength modulation operation to either narrow or wide range. As detailed in [Table 7](#), the operation characteristic of each range depends on the module type (X15 or E15/C15/Y15).

Table 7 Narrow vs wide band wavelength modulation

	Koheras BASIK X15	Koheras BASIK E15/C15/Y10
Narrow	Very limited modulation can be obtained, i.e. maximum ~30 MHz. Extremely low phase noise is maintained in this mode.	Maximum 0.8 GHz modulation for E15/C15 and 1 GHz for Y10.
Wide	Maximum 500 MHz modulation, but extremely low phase noise is NOT maintained in this mode.	Maximum 8 GHz modulation for E15/C15 and 10 GHz for Y10. Small negative impact on low frequency phase noise.

Frequency response For X15 modules, the frequency response of the wavelength modulation feature differs from that of the E15/C15/Y10 modules. The graphs in [Figure 17](#) (X15) and

Figure 18 (E15/C15/Y10) show the responses when the modulation signal varies from 1 to 100 kHz.

X15 frequency response

Figure 17 shows the measured frequency response of the BASIK X15 for both wide and narrow ranges:

- **Wide** – 500 MHz tuning at low frequencies with a smooth roll-off to a 3 dB cut-off at 300 Hz.
- **Narrow** – 30 MHz tuning with a slight peak at ~3 kHz.

Figure 17 BASIK X15 wavelength modulation response

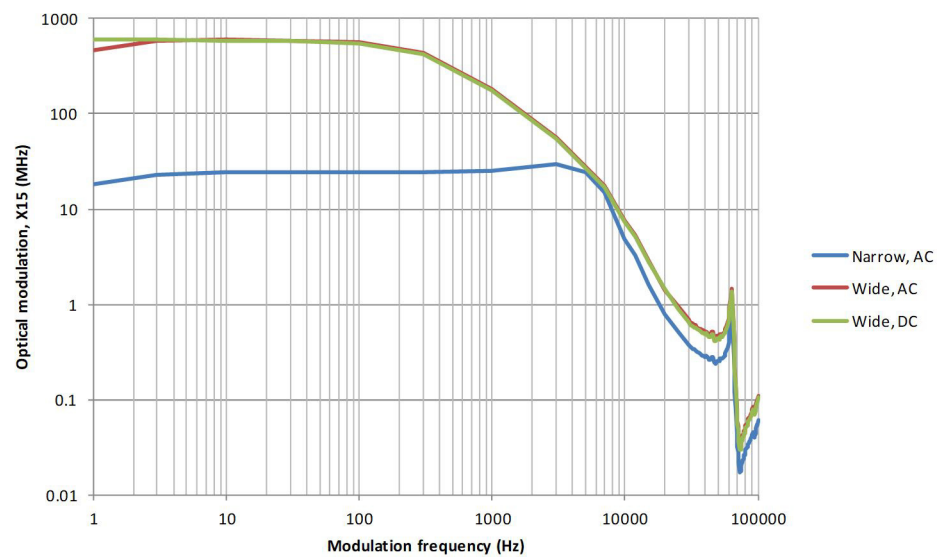

E15/C15/Y10 frequency response

Figure 18 shows the measured frequency response of the BASIK E15/C15/Y10 for both wide and narrow ranges:

- **Wide** – E15/C15 – 8 GHz with a 3 dB cut-off at 200 Hz
Y10 – 10 GHz with a 3 dB cut-off at 200 Hz

- **Narrow** – 10x (times) less with a 3 dB cut-off at 1 kHz

Figure 18 BASIK E15/C15/Y10 wavelength modulation response

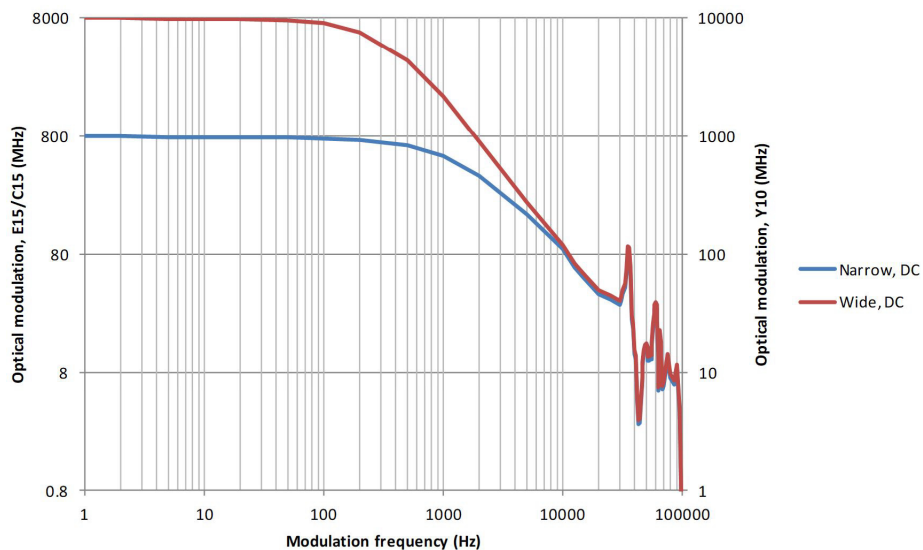

External cavity stabilization (BASIK X15)

An X15 module can be locked to an external cavity to obtain less low-frequency phase noise by using the Pound-Drever-Hall technique. Figure 19 depicts a general layout of the devices in a Pound-Drever-Hall configuration used with an X15 module.

Figure 19 BASIK X15 in Pound-Drever-Hall configuration

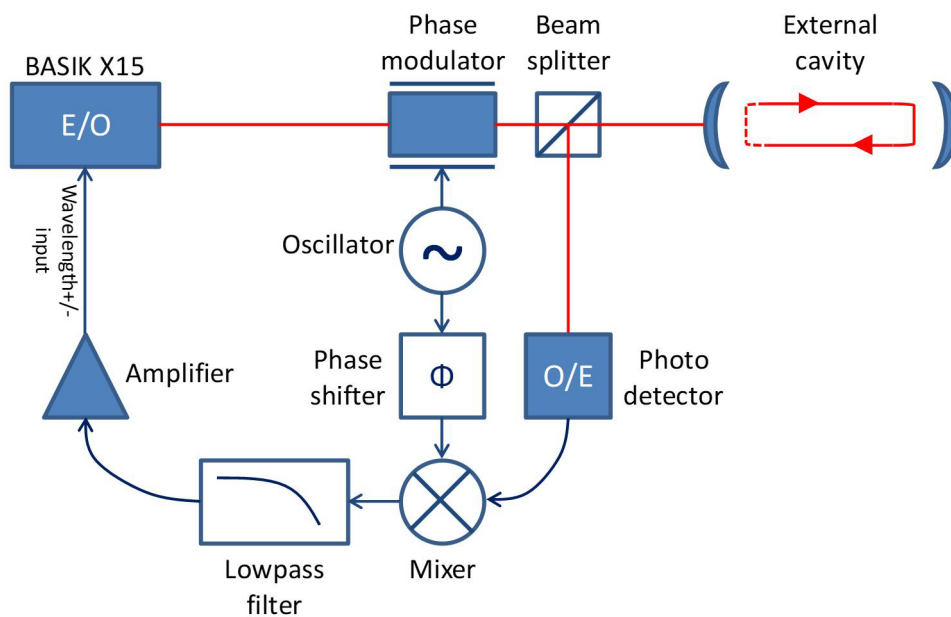

Setting up external cavity stabilization

Follow the steps below to configure and enable external cavity locking:

1. Enable external modulation (see [“Modulation source” on page 65](#)).
2. Configure the wavelength modulation input as DC coupled (see [“Modulation coupling” on page 67](#)).
3. Configure the module to operate in narrow modulation range (see [“Modulation range” on page 67](#)).
4. Turn on wavelength modulation (see [“Turning on wavelength modulation” on page 68](#)).
5. Set the update interval (see [“Integrating update interval” on page 68](#)).

Once enabled, the module constantly adjusts its wavelength so that the Pound-Drever-Hall loop results in a 0 V differential applied at the *Wavelength+/-* input pins.

When using external cavity stabilization, differential input is preferred to achieve the lowest noise performance.

SECTION 2

OPERATING THE LASER

This section describes how to manage and operate the laser and includes the chapters:

- “Communicating with the Laser” on page 49
- “Turning ON the Laser” on page 55
- “Using CONTROL” on page 59
- “Software Development Kit” on page 79

3

Communicating with the Laser

You can manage and control the laser using either:

- NKT Photonics CONTROL software (GUI) installed on a PC
- Or through the NKT Photonics Software Development Kit (SDK) to integrate the laser with a custom control system.

This chapter focuses on how to obtain and install both CONTROL or the SDK and then setup communications between a PC and the laser using the optional USB to RS-485 adapter.

Connection kit

To connect the laser directly to a PC using a USB connection, a connection kit from NKTP is available. The kit consists of the items listed in [Table 8](#).

Table 8 Koheras BASIK PC connection kit

Part Description
RS-485 adapter
BASIK interface board
DB15–IDC16 connectorized 15 cm ribbon cable
12 V 60 W power supply
15 A power cord C7 to EU/US/UK
USB cable – Type A to B

CONTROL software

The laser is shipped with the NKT Photonics CONTROL software installer on a USB key. You can also download the most recent CONTROL software from the following link:

<https://www.nktphotonics.com/lasers-fibers/support/software-drivers/>

The CONTROL software is capable of controlling, configuring and monitoring the laser.

Installing the software After downloading the CONTROL installer software onto a PC, double click the installer icon and follow the built-in wizard. Further details on installing the software is available in [Appendix E](#).

Software Development Kit

NKT Photonics provides an SDK for use when integrating the laser with your custom control system. You can download the SDK from the same URL where CONTROL installer is found:

<https://www.nktphotonics.com/lasers-fibers/support/software-drivers/>

To install the SDK, run the installer and follow the instructions of the install wizard.

Generic User Interface The installer includes the Generic User Interface software as part of the SDK. This guide gives brief instructions on using the Generic User Interface to access and modify registers containing operation parameters of the laser (see “Software Development Kit” on page 79).

Note: For a full description of the SDK, registers and the Generic User Interface, refer to the NKT Photonics document: *SDK Instruction Manual*. The manual is installed along with the SDK components when the SDK installer is run.

Connecting CONTROL to the laser

You can manage the laser using its RS-485 serial connection connected to a PC with CONTROL installed on it. You can use the NKT Photonics RS-485 connection kit including the BASIK interface board to connect the laser to the PC’s USB port. The kit is intended to help test the laser when integrating it with a custom system. Follow the steps in Procedure 1 to connect CONTROL to the laser using the kit.

Procedure 1 Connecting CONTROL to the laser

Action	
1	<ol style="list-style-type: none"> a. Connect a BASIK interface board to the main interface connector of the laser. b. Using an IDC 16 pin to DB-15 ribbon cable, connect an NKT Photonics RS-485 adapter to the 16 pin main interface connector on the BASIK interface board. c. Connect an RS-485 adapter to your PC using a USB-A to USB-B cable. d. To power on the laser, connect the power supply to the RS-485 adapter power jack and AC mains.

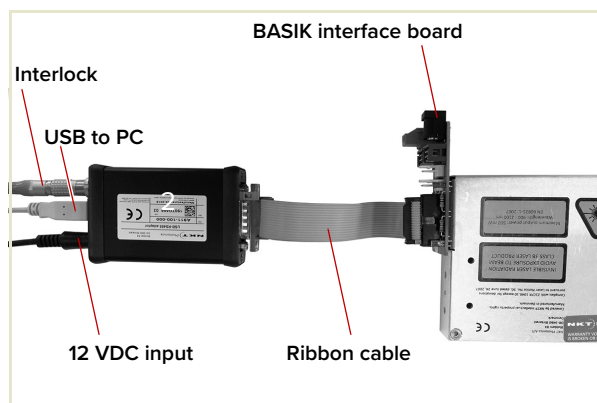

Note: Connect either a door safety switch circuit to the LEMO connection of the adapter or use the adapter defeater shown in Figure 74.

Action

2 Launch CONTROL by either:

- clicking on Windows – Start – Programs – NKT Photonics – CONTROL
- or –
- double clicking the CONTROL shortcut on the desktop



3 The CONTROL window opens.

Click on the “Connect” button in the left side of the window.

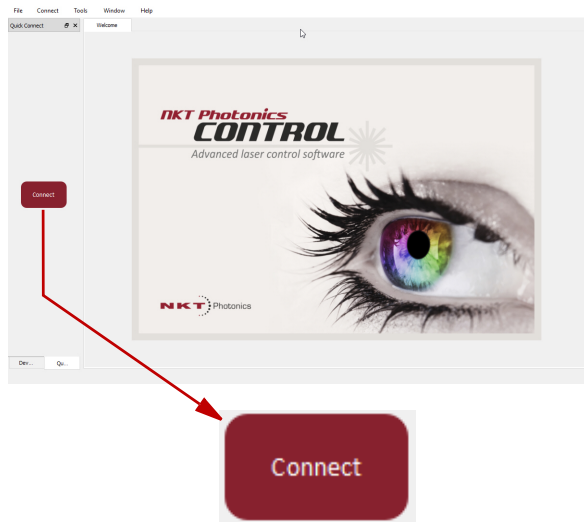

4 CONTROL automatically scans for any connected lasers and accessories available on both COM and configured Ethernet ports.

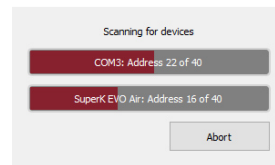

5 CONTROL connects with the laser.

In the status panel of CONTROL, the Status indicator is AMBER. The indicator turns GREEN when the laser thermalization set point is reached.

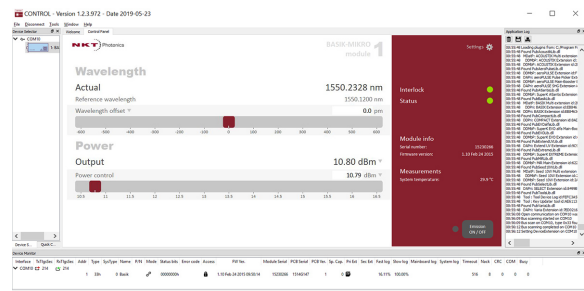

Connecting the SDK GUI to the laser

You can manage the laser using its RS-485 serial connection connected to a PC with the SDK installed on it. The SDK includes a Generic User Interface (GUI) that can read and write registers in the laser module. You can use the NKT Photonics RS-485 connection kit including the BASIK interface board to connect the laser to the PC's USB port. Follow the steps in [Procedure 2](#) to connect the SDK Generic User Interface to the laser.

Procedure 2 Connecting the SDK Generic User Interface to the laser

Action

- 1
 - a. Connect a BASIK interface board to the main interface connector of the laser.
 - b. Using an IDC 16 pin to DB-15 ribbon cable, connect an NKT Photonics RS-485 adapter to the 16 pin main interface connector on the BASIK interface board.
 - c. Connect an RS-485 adapter to your PC using a USB-A to USB-B cable.
 - d. To power on the laser, connect the power supply to the RS-485 adapter power jack and AC mains.

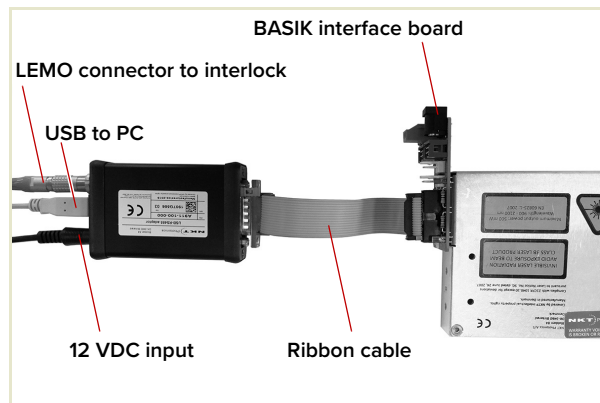

Note: Connect either a door safety switch circuit to the LEMO connection of the adapter or use the adapter defeater shown in [Figure 74](#).

- 2 Launch the Generic User Interface by clicking on:

Windows – Start – Programs – Generic User Interface



- 3 The Generic User Interface window opens.

- a. Under “Communication Interface” - select USB/Serial
- b. Click on the “Comm” button in the upper left region of the window and select the USB port connected to your PC.
- c. In the Module Address field, enter: 1
- d. Click the “Connect” button.

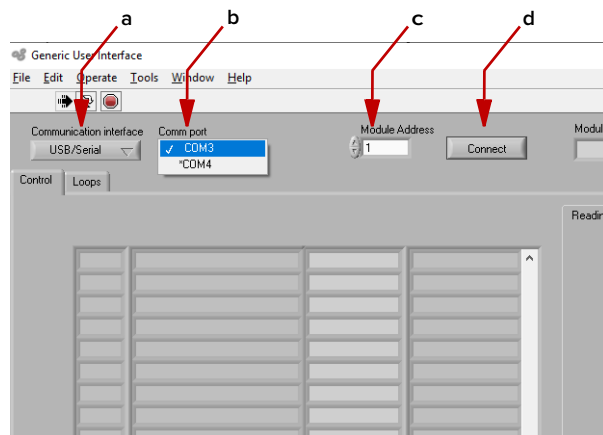

Action

4 The Generic User Interface connects to the laser and displays the current register values.

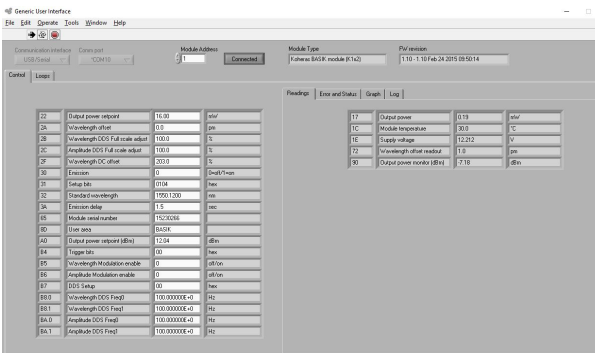

4 Turning ON the Laser

Safety

Before you turn ON the laser, ensure that you are completely familiar and follow all safety information and recommendations stated within this document and the document:

Koheras BASIK Safety, Handling and Regulatory Information

Ensure also to follow all regional laser safety regulations required for your location.

Preparation

The laser is ready to be turned on when the following steps are completed.

1. The laser is securely installed and connected according to the procedures in “[Mechanical Installation](#)” on page 93 and “[Connecting the Laser](#)” on page 97. This means the laser is: installed in an environment that meets recommendations, power is applied and at the very minimum an access door switch is connected to the interlock.
2. The laser is connected to a PC using an RS-485 adapter and the PC has CONTROL installed on it and executing according to the procedures in “[Communicating with the Laser](#)” on page 49.
3. The FC/APC connector is placed so that any emissions are safely contained within the working application such as a beam dump that can absorb the emitted beam power.



Warning: Turning on the laser emits hazardous laser Class 3B radiation. Ensure to observe and implement all safety regulations, warnings and cautions in this guide and the *Koheras BASIK Safety, Handling and Regulatory Information* document before continuing.



Warning: Ensure the fiber connector face (tip) is clean. Optical power transmitted through the connector may burn particles on the connector face damaging it.



Note: When connecting the output fiber patch cord, ensure to match it with an appropriate fiber type.



Caution: Do not turn on the laser if it has been exposed to temperature and humidity beyond the operating specifications. The laser is designed to operate in a non-condensing environment from +15°C to +60°C. Before turning on the laser, allow it at least 30 minutes to stabilize at the operating room temperature. Turning on a laser that is too cold or hot may lead to the system being damaged.

Controlling the laser emissions

Turning On the laser To turn on the laser using CONTROL follow the steps in [Procedure 3](#). To turn it on using the Generic User Interface use [Procedure 4](#).

Note: The laser is equipped with internal temperature sensors that monitor the temperature of sensitive components. If these components are outside their specified temperature range, the laser source halts emission.

Procedure 3 Turning on the laser using CONTROL

Action	
1	Connect to the laser as described in Procedure 1 .
2	<p>Check in the CONTROL status panel that the <i>Interlock</i> indicator shows ON Green and the <i>Status</i> indicator displays ON Amber.</p> <p>Click the <i>Emission ON/OFF</i> button to turn on laser emission.</p> <p>Note: On the laser's front panel, the LEDs should indicate as follows: <i>Power</i>—ON Green <i>Status</i>—ON Amber <i>Interlock</i>—ON Green <i>Emission</i>—ON Red</p>
3	<p>When the <i>Status</i> indicator turns ON GREEN, the laser thermalization set point is reached and stabilized.</p> <p>Note: At this point, the laser <i>Status</i> LED should also be lit ON Green.</p>
4	<p>a. In the Control panel, set the reference wavelength (λ) or its offset using the <i>Wavelength or offset</i> slider control. To set it, click hold and move the red slider to adjust the setting.</p> <p>b. Alternatively, you can directly enter the wavelength (nm) or offset (pm) by typing the value into the wavelength input text field at the upper right side of the control.</p> <p>c. Set the laser's emitted power using the <i>Power</i> slider. To change the power, click hold the red slider to adjust its position along the bar.</p> <p>d. Alternatively, you can directly enter the output power in dBm or mW by typing the value into the power input text field at the upper right side of the control</p> <p>NOTE: To set the scale units, click on the downward pointing arrows for both the wavelength and power settings.</p>

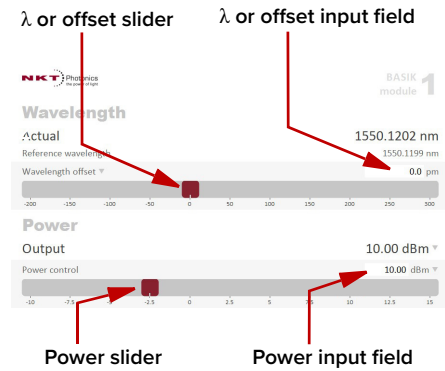
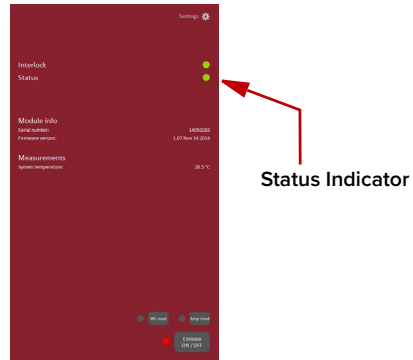

Procedure 4 Turning on the laser using the Generic User Interface

Action

1 Connect to the laser as described in Procedure 2 .

- 2 a. Launch the Generic User Interface.
- b. Select the correct USB COM port from the Comm port drop down menu.¹
- c. Set the module address to 1.
- d. Click Connect

CONTROL connects to the laser.

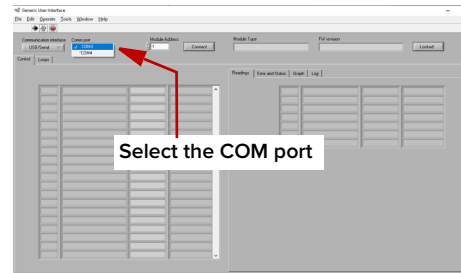

3 a. Locate register 30 *Emission* in the CONTROL tab.

- b. In the register's text field, input 1 and press the enter button to turn on the laser.

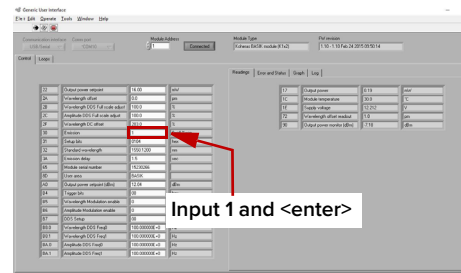

4 Click on the *Error and Status* tab in the right side of the window and verify the *Emission* indicator is lit green.

Note: You can also check the laser's *Emission* status LED.)

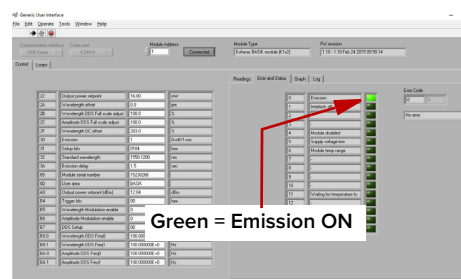

5 Click on the *Graph* tab and then select the parameters of the graph's axis from the drop down menus at top and bottom of the graph.

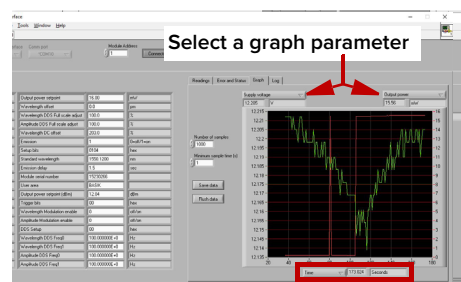

1. The COM port connected should have an asterisk (*) next to it in the list.



Note: For a full description of the SDK, registers and the Generic User Interface, refer to the NKT Photonics document: *SDK Instruction Manual*. The manual is installed when the SDK installer is run.

5 Using CONTROL

CONTROL overview

The CONTROL interface includes multiple panels and a selection of menu drop down items in the upper left corner. Using the Window drop down menu, you can add or remove the displayed panels and panels can be dragged within the main window or into separate windows. The panels and menu shown in [Figure 20](#) are briefly described [Table 9](#) with links to more details descriptions.

Table 9 CONTROL panels and menu items

Panel	Function	See
Status Panel	This panel displays the selected device status, emission control and a CONTROL settings menu.	Status panel on page 63
Menu Items	Four drop down menus with multiple functions.	CONTROL menu items on page 72
Quick Connect	Contains a button when clicked, scans all available PC ports for connected NKTP products.	Connecting to the laser on page 61
Device Selector	Icons representing currently connected devices, click to access the device.	Device selector on page 62
Control Panel	The <i>Control</i> panel contains controls for the laser. For example, It contains configuration controls to set wavelength and output power.	CONTROL – Control panel on page 75
Application Log	This panel displays a debugging log that can be saved to a file.	Application log on page 78
Device Monitor	To help debug communication issues, this panel displays multiple port and device module parameters.	Device Monitor on page 77

Figure 20 GUI panel navigation

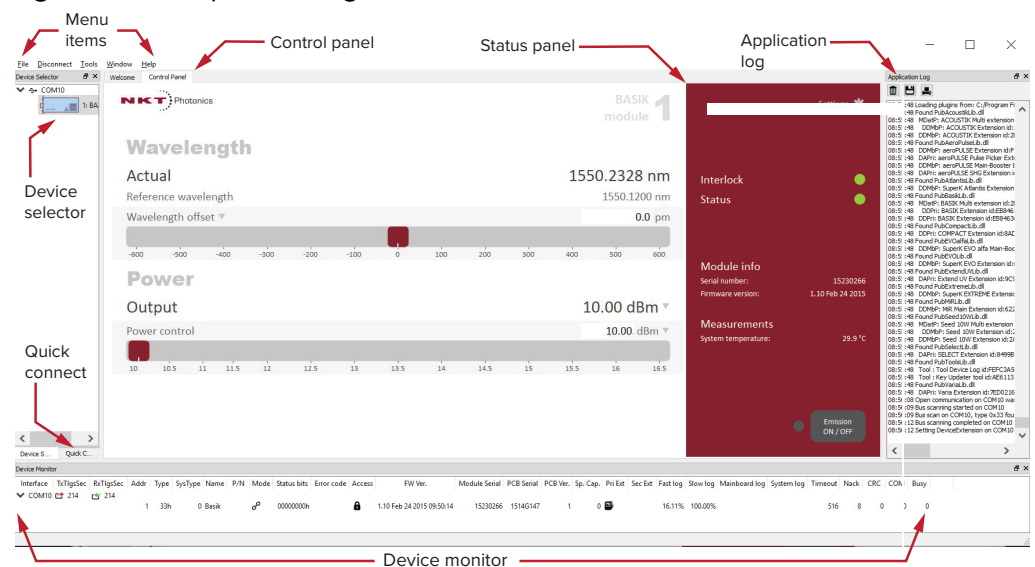

Relocating panels You can drag the different panels of CONTROL to any location within the main interface or into a separate floating panel. **Procedure 5** describes how to relocate a panel within the main window.

Procedure 5 Relocating panels

- Action**
- 1 Left click and hold the top title bar of the panel.
 - 2 While holding the left mouse button down, drag the panel to another location in the main window.
 - 3 In the new location, when the background turns blue, release the mouse button – see **Figure 21**.
 - 4 Alternatively, drag the panel out from the main window and release the mouse button. A separate window for the panel is created. (see **Figure 22**)

Figure 21 Relocating panels within CONTROL

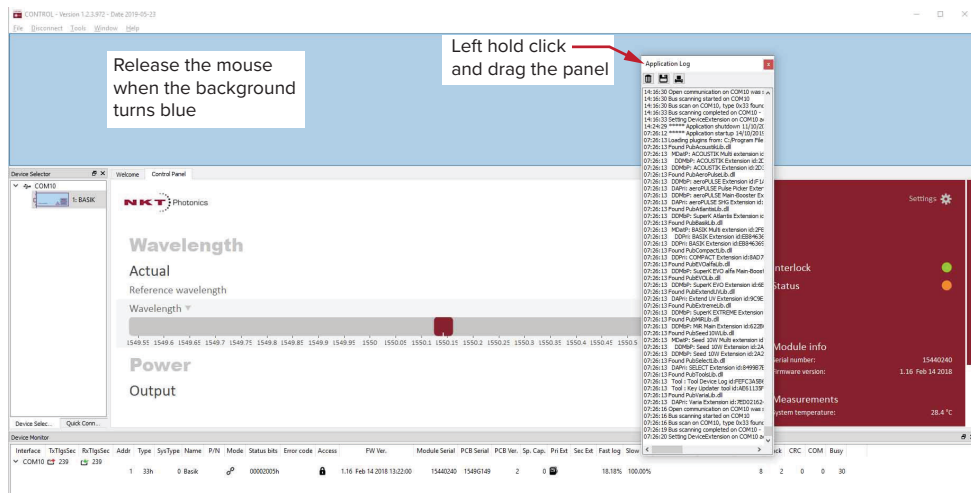
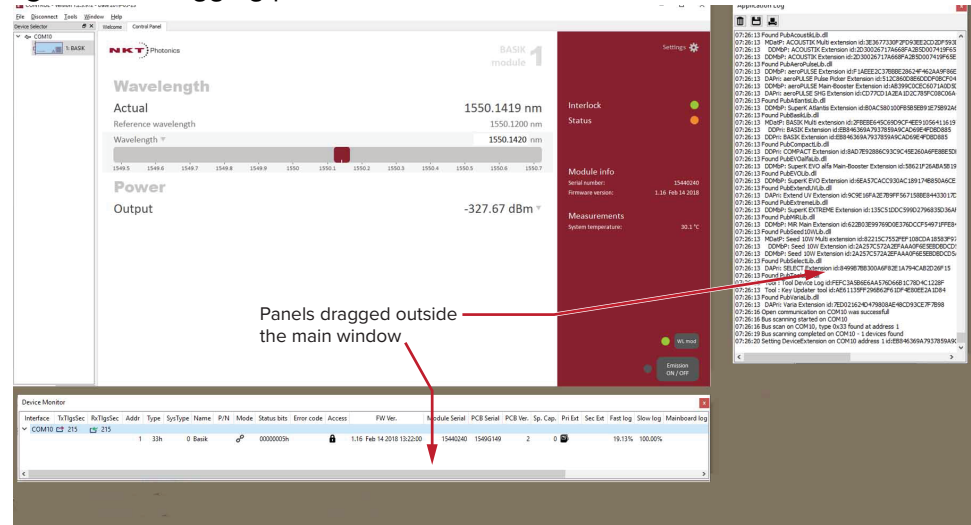
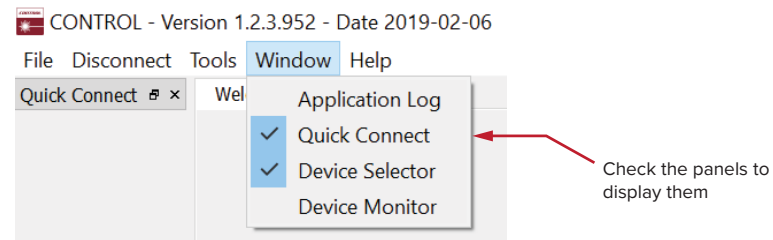

Figure 22 Dragging panels outside the main window



Toggle panels visible Use the Menu > Window drop down menu to check and uncheck panels to be displayed. A blue check mark indicates the panel is displayed.

Figure 23 Toggling panel visibility



Note: To close a panel, click the X at the upper right corner of the panel.

Connecting to the laser When CONTROL is launched, the *Welcome* screen is displayed as in [Figure 24](#). In the menu bar, click the *Connect* drop down menu and then click on the COM port your laser is connected to. *Control* and *Status* panels are displayed when the laser connects to the GUI.

See “[Connecting CONTROL to the laser](#)” on page 50

Figure 24 Welcome screen and connecting

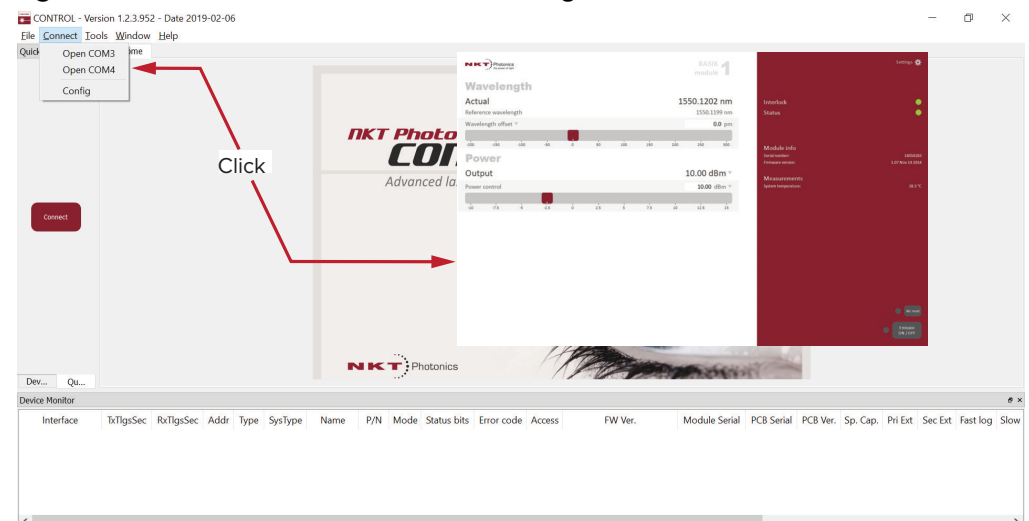

Quick connect

Click the *Connect* button and CONTROL scans all available ports for NKT devices that it can connect to. Once CONTROL finishes the scan, a list of the devices is presented.

Figure 25 Connect button



Device selector The *Device Selector* panel shows an icon for each connected device. [Figure 26](#) shows the device selector for an BASIK laser. If multiple lasers are detected by CONTROL, click on the BASIK icon to bring up its controls. To modify the ICON text, see [“View” on page 71](#).

Figure 26 Device selector panel

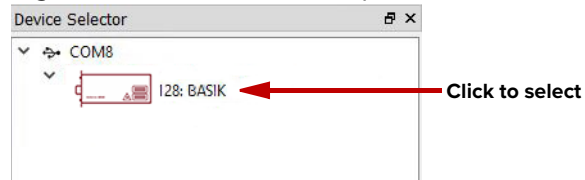

Status panel

The status panel provides status indicators, error messages, emission controls and a settings drop down menu.

Figure 27 Status panel



Status indicators The panel displays the following indicators:

Interlock

Indicates if power is connected to the laser.

- ON Green – The interlock circuit is closed and emission is allowed.
- ON Red – The interlock circuit is open or needs a reset and emission is prohibited.

Status

Indicates the laser's thermalization and error status:

- ON Green – The laser has reached its set point operating temperature and has stabilized.

- ON Amber – The laser is in the process of warming up or an error is detected.

Module info The *Module Info* section shows the following:

- Laser serial number
- Laser firmware revision

Measurements Displays the system temperature.

WL mod button and **Button**

indicator The *WL mod* button enables or disables wavelength modulation.

Indicator

GREEN – wavelength modulation is enabled.

GREY – wavelength modulation is disabled.



Note: The *WL mod* button and indicator is only displayed by CONTROL if the wavelength modulation feature is included with the laser.

Emission button The *Emission* button turns the laser emission ON or OFF – see “[Controlling the laser emissions](#)” on page 56.

The button’s indicator turns ON RED when laser emission is generated. Otherwise, it is OFF GREY.



Warning: When the *Emission* button LED is ON RED, laser emission is rated Class 3B is present.

CONTROL settings



The GUI settings are accessible by clicking the gear icon  in the upper right corner of the status panel. Clicking the gear icon displays a menu of setting items as shown in [Figure 28](#).

Figure 28 GUI settings

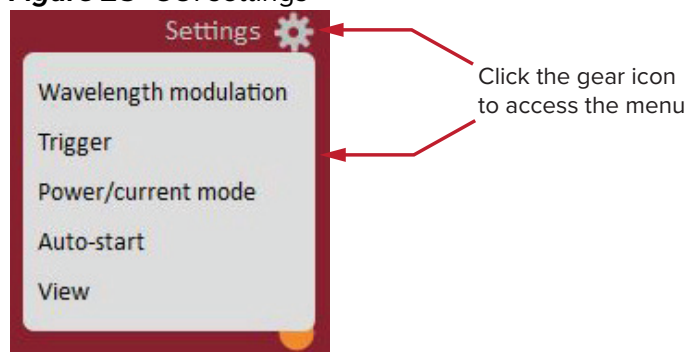

Setting Item	Function	See
Wavelength modulation	Toggles the mode of the laser between power and current mode.	Wavelength modulation on page 65
Trigger	Configures the trigger pin behavior.	Trigger on page 69
Power/current mode	Drop down menu to select the laser operation mode.	Power/Current mode on page 70
Auto-start	Checkbox to toggle Auto-start on or off.	Auto-start on page 71
View	Menu with a checkbox to enable displaying the System Information on the status panel.	View on page 71

Wavelength modulation The wavelength of the laser can be modulated using either the laser's internal function generator or an external signal. From the *Settings*  drop-down menu, select *Wavelength modulation*. Depending on the modulation source selected, [Figure 29](#) to [Figure 31](#) show the *Wavelength modulation* menus displayed. Within these menus you can configure multiple parameters that affect the modulation functionality.



Note: The *Settings - Wavelength modulation* menu item is only available if the module includes the wavelength modulation feature.

Modulation source

The source signal used to modulate the wavelength is selectable. Click on the *Source* drop-down menu to select one of three source modes:

- **Internal** ([Figure 29](#)) – wavelength is modulated using the laser's internal function generator.
- **External** ([Figure 30](#)) – wavelength is modulated by connecting an external signal to the *Wavelength+-* pins.
- **Both** ([Figure 31](#)) – both internal and external signals simultaneously modulate the wavelength.

You can connect an external signal to either the BASIK interface board connectors as described in “Connecting modulation signals” on page 99 or directly to the main electrical interface pins. The pin assignments are described in Table 19 on page 113. For information regarding example external signal generation circuits, refer to section “Fast wavelength modulation” on page 37

Figure 29 Wavelength modulation - internal source

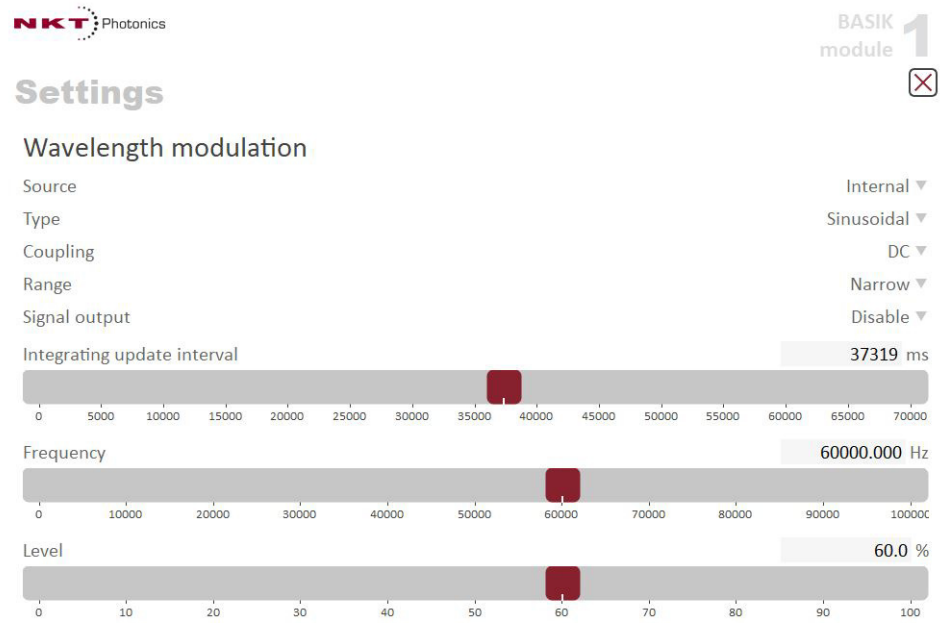

Figure 30 Wavelength modulation - external source

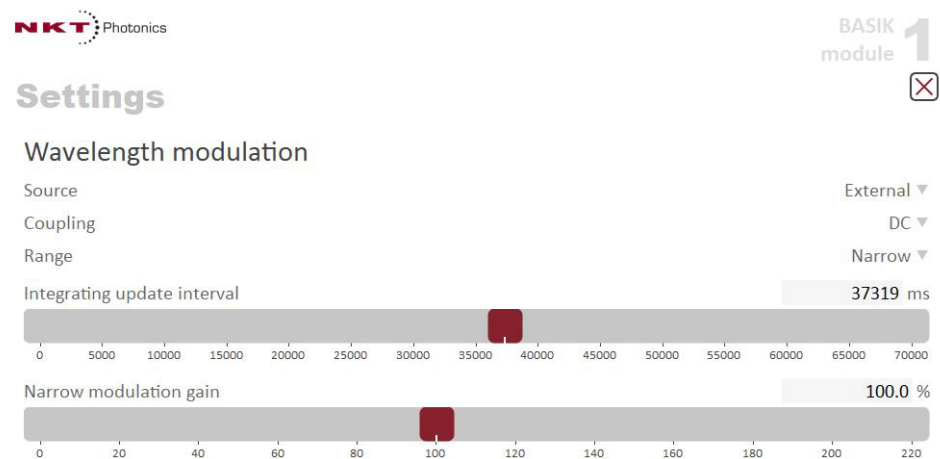
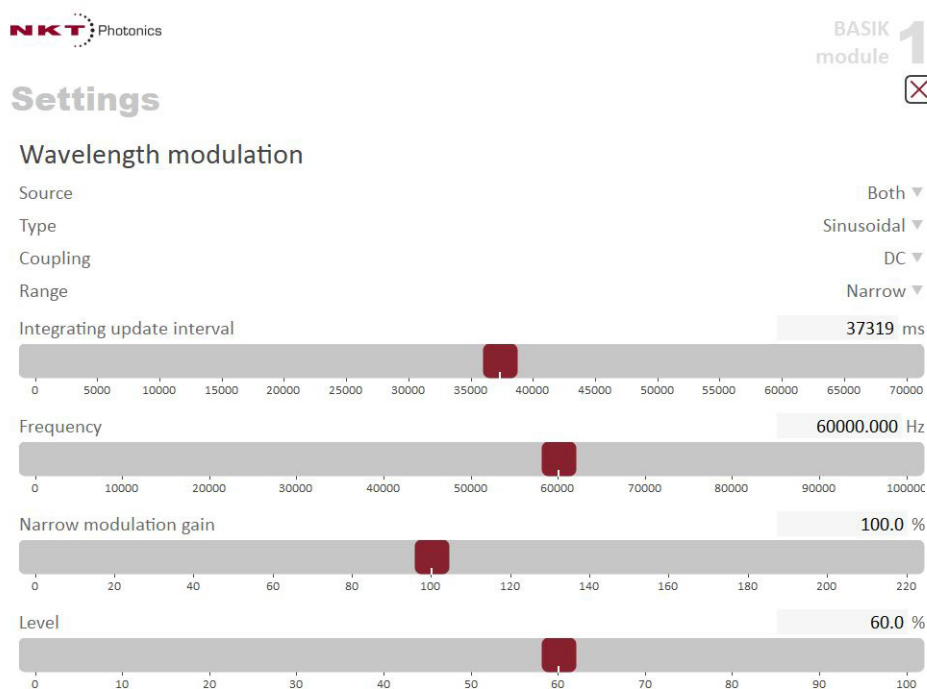
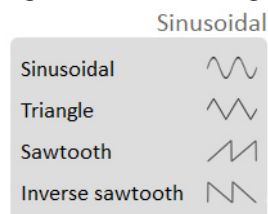

Figure 31 Wavelength modulation - both**Modulation type (internal mode)**

If the modulation *Source* is set to *Internal*, you can set the signal waveform type that is generated internally. Click the *Type* drop-down menu arrow and select either *Sinusoidal*, *Triangle*, *Sawtooth* or an *Inverse sawtooth* waveform.

Figure 32 Internal generator waveform selection – *Type* setting**Modulation coupling**

You can select to couple the modulation signal using either AC or DC coupling. Click on the *Coupling* drop-down menu arrow and select either AC or DC coupling. Refer to “[Wavelength modulation coupling](#)” on page 42 for further information.



Note: When using wavelength modulation with an X15 module, and the modulation *Range* parameter is set to *Narrow*, the modulation signal will be AC-coupled and the DC-component enters a software integrating function that tunes the wavelength up or down when the DC-voltage varies either positive or negative respectively. The speed of wavelength tuning is set with the *Integrating update interval*.

Modulation range

For X15 modules, you can use the modulation *Range* drop-down menu to set the modulation range to either *Narrow* or *Wide*.

When set to *Narrow*, modulation depth is limited but the X15's low phase noise is maintained. To increase the modulation depth, change the *Range* setting to *Wide*. When set to *Wide*, phase noise increases.

Note: Refer to “[Narrow versus wide modulation range](#)” on page 42 for further information on configuring the modulation range.

Signal output

You can output the internal generator signal (internal modulation) from the wavelength modulation pins of the laser. To output the signal from the pins, set the modulation *Type* to *Internal* and the *Signal output* selector to *Enabled*. To disable the signal output, set the *Signal output* drop-down menu to *Disabled*.

When multiple lasers are used, one laser can be used as a master signal generator and all other lasers configured as slaves.

1. On all lasers, connect the *Wavelength+* pins together and the *Wavelength-* pins together.
2. Designate one laser as the master by setting it to operate in *Internal* modulation mode (*Source*) and *Signal output* set to *Enabled*.
3. Set all other laser's to operate in slave mode by setting them to operate in *External* modulation mode (*Source*).

Integrating update interval

You can set the update interval of the software integration function with this setting. The setting is intended for use with X15 modules when they are set to *DC* coupling and *Narrow* modulation range.

Internal generator frequency

When the modulation source is set to *Internal*, the frequency of the internal generator signal is adjustable from 8 MHz (0.008 Hz) to 100 kHz (100,000 Hz). To adjust the frequency, use either the slider or the text input field at the upper right corner of the slider.

Narrow and wide modulation gain

You can use this slider to increase the gain of an external modulation signal applied to the *Wavelength+/-* pins. Increasing the gain directly increases the wavelength modulation achievable with the signal.

Internal generator power level

You can set the output power level of the internal function generator to between 0 and 100%. Use the slider or the field in the upper right corner of the *Level* slider to adjust the modulation level.

Turning on wavelength modulation

To enable wavelength modulation, in the lower right of the status panel click the WL mod button. The indicator next to the button turns ON green. Clicking the button again turns off the feature.

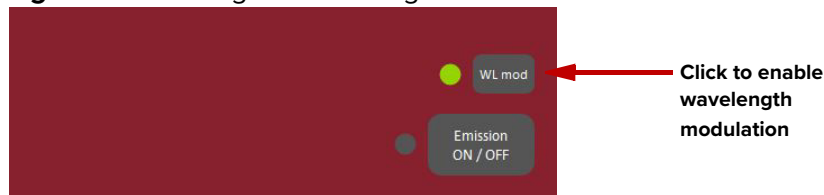
Figure 33 Turning on wavelength modulation

Trigger The trigger function can initiate emission using an input logic trigger signal or it can output a logic trigger signal when emission is enabled. The trigger signal output or input is connected to pin B4 of the main electrical interface (see [Table 19](#)).

Trigger type

Click the pull-down menu arrow to select either:

- *Trigger Type: Input* ([Figure 34](#))
 - *Input trigger action: None* – no voltage on pin B4.
 - *Input trigger action: Emission* – if a logic high voltage is applied to pin B4, laser emission is enabled.
 - *Input trigger action: Sawtooth Wavelength Modulation* – When this option is selected, the sawtooth signal from the internal generator enables emission on the rising edge and disable emission on the downslope of the signal. The sawtooth signal is controlled from the *Wavelength modulation* setting page by setting *Source* to *Internal* and *Type* to *Sawtooth*. Then, adjust the signal using the sliders on the same page.
- *Trigger Type: Output* ([Figure 35](#))
 - *Output source: None* – no voltage on pin B4
 - *Output source: Emission* – when laser emission is enabled, pin B4 is set to a logic high voltage.
 - *Output source: Sawtooth Wavelength Modulation* – Selecting this option outputs the internal function generator (set to Sawtooth) from pin B4. The sawtooth signal is controlled from the *Wavelength modulation* setting page by setting *Source* to *Internal* and *Type* to *Sawtooth*. Then, adjust the signal using the sliders on the same page.

Figure 34 Trigger type – Input

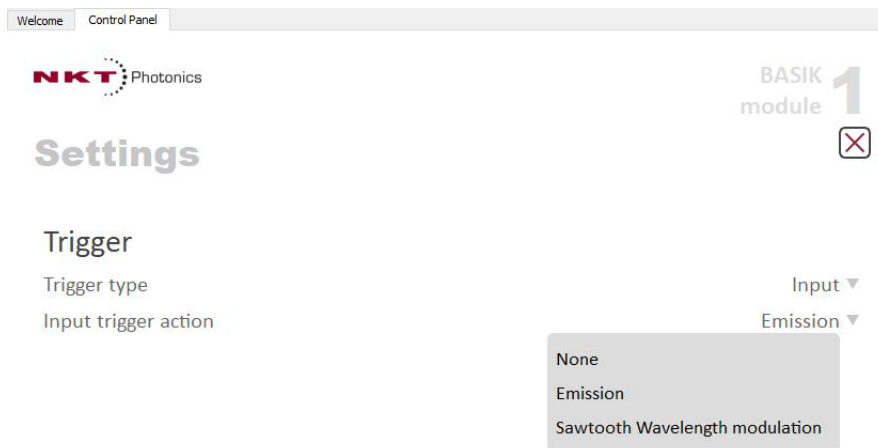
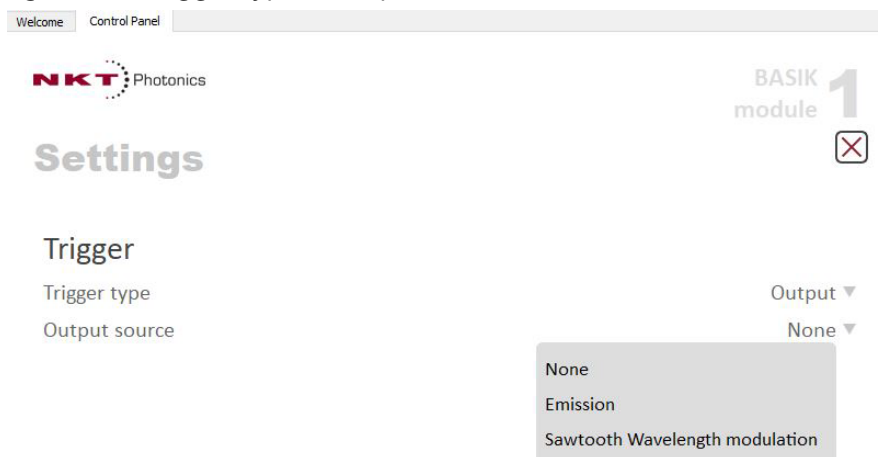
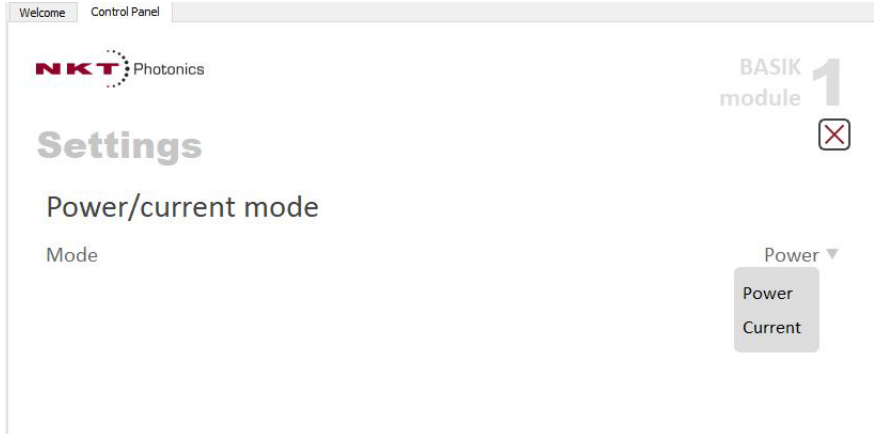

Figure 35 Trigger type – Output



Power/Current mode You can set the laser output *Mode* to either *Power* or *Current* as described in “[Operating mode](#)” on page 29. Click the menu item shown in [Figure 36](#) to toggle the mode. The *Control* panel automatically switches the controls displayed for the new mode.

Figure 36 Power and current mode controls



Auto-start To enable the “Auto-start” function, select the *Auto-start* checkbox.

Figure 37 Auto-start setting

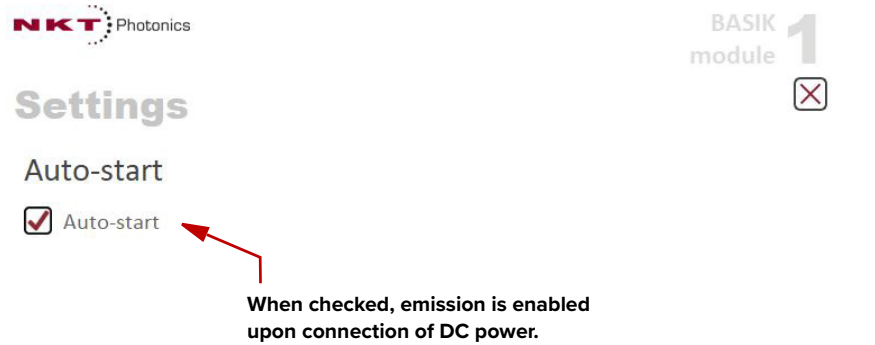

View Select the *Module info* checkbox to display the laser serial number, firmware release number or system temperature within the status panel. Select the *Measurements* checkbox to display the system temperature in the status panel.

Figure 38 View setting

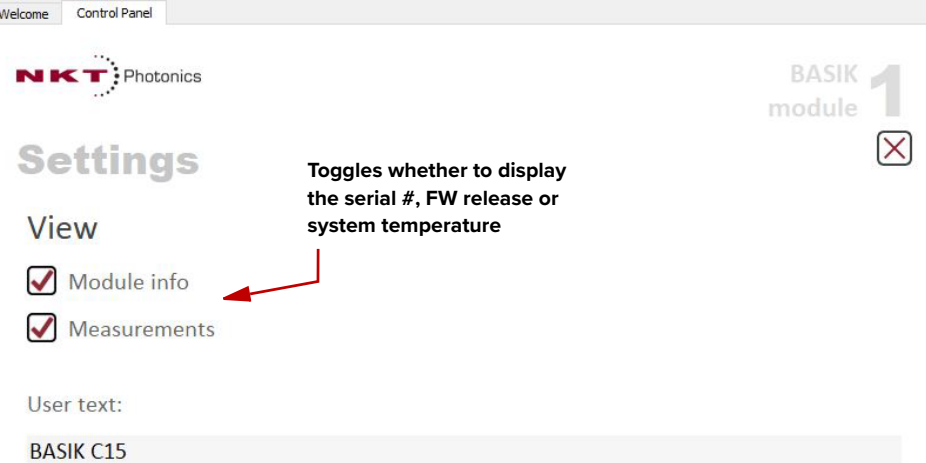

CONTROL menu items

There are five drop down menus in the main control window as highlighted in [Figure 39](#). Click on the items in the menu to reveal the drop down menus.

Figure 39 Menu items

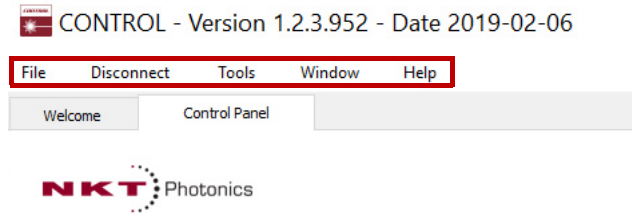

Menu Item	Function
File	Click <i>File>Exit</i> to exit the CONTROL program
Disconnect	Click <i>Disconnect>Close All</i> to disconnect the currently connected device from CONTROL.
Tools	Select from one of three special tools to use with your laser. Tools available are: <ul style="list-style-type: none"> • Key Updater tool on page 72 • Log Downloader on page 73 • Extensions Overview on page 74
Window	Sets whether certain panels are visible or not – Toggling panels visible on page 61 .
Help	Displays the current version of CONTROL and access to CONTROL user help.

Key Updater tool The Key Updater tool applies special features and corrections to modules and systems of the laser.

To use the Key Updater tool follow [Procedure 6](#).

Procedure 6 Using the Key Updater tool

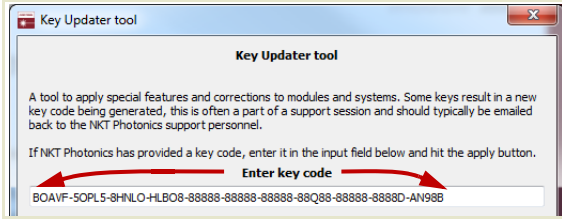
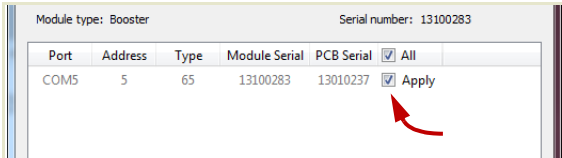
Action	
1	 <p>Enter a key code in the field “Enter key code”.</p> <p>NOTE: Key codes are generated by NKT Photonics.</p>
2	 <p>In the list of modules, check the box on the right of each applicable module.</p>

Action

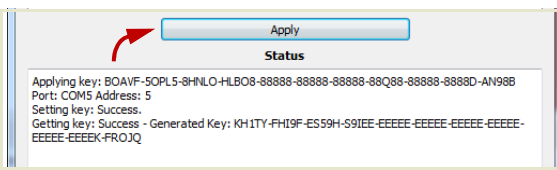
3  Click "Apply"

Note: Certain keys can generate a new locally generated key code. These locally generated keys are usually required during a support session and are sent to NKT Photonics support personnel.

Log Downloader If your laser requires support from NKT Photonics, our support engineers may request you send them log files collected by the laser. You can use the log downloader tool to save laser log files to your CONTROL PC.

NKTP CONTROL automatically downloads log files from modules of any connected devices. The log files are stored in a local database of the CONTROL PC. However, certain NKTP modules, including the Koheras BASIK mainboard, do not support automatic download of log files. For these modules, you can use the Log Downloader tool to put the device into dedicated log download mode by enabling a collect log function.

Note: When the collect log function is enabled, it temporarily disables automatic log collection from all other devices. The CONTROL interface turns gray, and communication with the laser and log collection with all other modules is disabled

To download log files, use the Log Downloader as described in [Procedure 7](#).

Procedure 7 Using the Log Downloader

Action

1 Click the *Tools* menu and click on *Log Download* to start the Log Downloader tool.

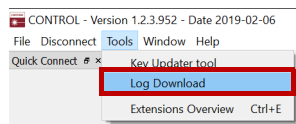

2 The tool displays all connected modules with log capability. To decrease the download time of the module log files, CONTROL continuously collects module log data and stores this log data in a local database on the PC. Logs are collected from each module and each has a percentage indicator that shows the percentage (%) collected of the module's total log data.

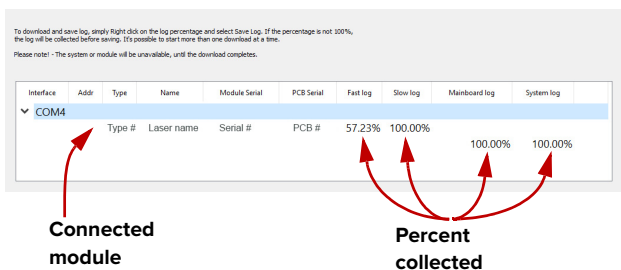

Interface	Addr	Type	Name	Module Serial	PCB Serial	Fast log	Slow log	Mainboard log	System log
COM4		Type #	Laser name	Serial #	PCB #	57.23%	100.00%	100.00%	100.00%

Action

3 To download and save a log file to the CONTROL PC, right click the percentage indicator and select either:

- **Save log** – Immediately saves the file onto the CONTROL PC. If the percentage shows less than 100%, the log is first collected. See Collect log below.
- **Collect log** – Starts a dedicated log collection mode that disables all other CONTROL activity.

4 If you select *Save log*, a dialog box prompts for a filename and folder to store the log in.

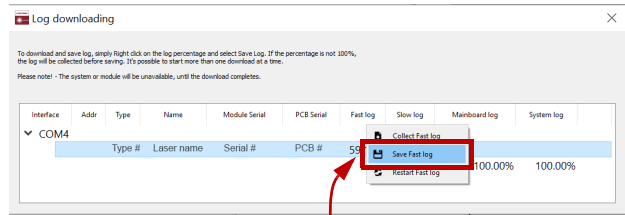

Right click the % indicator

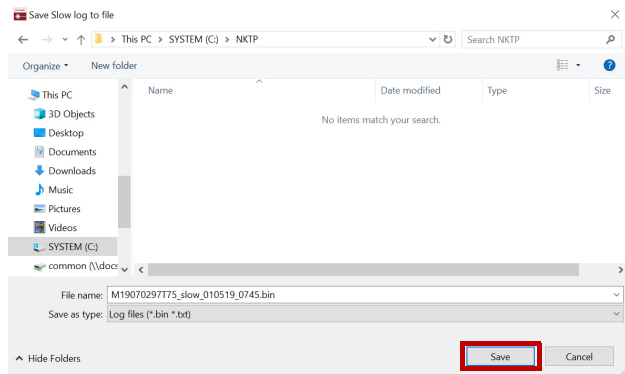

5 If you select *Collect log*, the log is collected and saved in dedicated mode. The CONTROL panel turns grey and all other functions are disabled.

When the log collection is finished, all other CONTROL functions are accessible again.

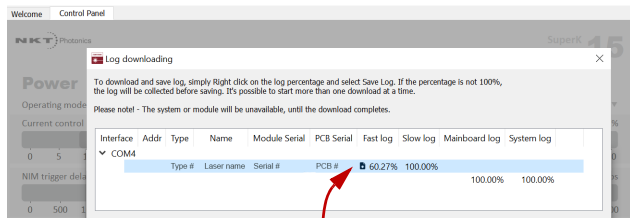

Dedicated Collection Mode

6 Select *Restart* to clear out all collected log data and restart log data collection.

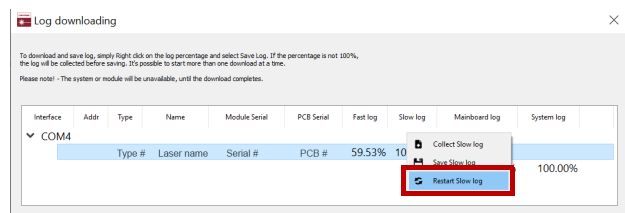

Extensions Overview Use this tool to view the installed extensions (similar to plugins) that are included with CONTROL. The extensions are found in the following folder:

C:\Program Files (x86)\NKT Photonics\NKTP CONTROL\Plugins

To view the extensions, open the Tools menu and click on Extensions Overview. The Extensions Overview window is launched as shown in Figure 40.

Figure 40 Extensions Overview

Extension	Modules	Type
ACOUSTIK Extension	(0x34, 0) Acoustik, at all addresses	Mainboard Device Primary
ACOUSTIK Extension	(0x34, 1) Adjustik, at all addresses	Mainboard Device Primary
ACOUSTIK Extension	(0x34, 0) Acoustik, at all addresses	Mainboard Device Primary
ACOUSTIK Extension	(0x34, 1) Adjustik, at all addresses	Mainboard Device Primary
PubAeroPulseLib.dll - 1.0.8.302 - Release notes		
SuperK aeroPULSE Extension	(0x71, 0) AeroPulse, at all addresses	Mainboard Device Primary
aeroPULSE Pulse Picker Extension	(0x7B, 0) Pulse Picker, at all addresses	Accessory Primary
aeroPULSE Main-Booster Extension	(0x78, 1) aeroPULSE Main-Booster, at all addresses	Mainboard Device Primary
PubBasikLib.dll - 1.1.2.303 - Release notes		
BASI K Multi extension		Multi-Primary
BASI K Extension		
BASI K Extension		
PubCompactLib.dll - 1.0.5.257 - Release notes		
COMPACT Extension		
PubEVO Lib .dll - 1.0.0.305 - Release notes		
SuperK EVO Main-Booster Extension		
PubExtendUV Lib .dll - 1.0.4.257 - Release notes		
Extend UV Extension		
PubExtreme Lib .dll - 1.0.5.257 - Release notes		
SuperK EXTREME Extension	(0x00, 0) Extreme, at all addresses	Mainboard Device Primary
PubMiRLib.dll - 1.0.5.276 - Release notes		

BASIK plugin release notes

- 1.1.2 Corrected integrating control slider visibility issue.
- 1.1.1 Corrected slider control calculations.
- 1.1.0 Corrected some minor bugs related to phase shift compensation.
- 1.0.9 Corrected bug regarding sliders sometimes being to short.
- 1.0.8 Corrected a wavelength slider enable issue in Basik-mikro.
- 1.0.7 Implemented support for new functions in Basik PCB version 2.
- 1.0.6 Corrected some features, in Basik-mikro.
- 1.0.5 Added new features and Basik-mikro support.
- 1.0.4 Initial release.



Note: To show a short description of the release notes as seen in [Figure 40](#), hover the mouse pointer over the “Release notes” text

The PubBasikLib.dll details highlighted in [Figure 40](#) shows the version of the .dll file (1.1.2.303), the included extensions and which module types they support.



Note: Multiple extensions for a wide range of NKTP lasers types are typically installed when using the default installation of CONTROL.

CONTROL – Control panel

For the Koheras BASIK the control panel can be configured to present different operating mode controls for either Power or Current mode. The modes are selected by clicking on the Settings drop down menu (gear icon) in the status panel. See “[CONTROL settings](#)” on [page 65](#). The wavelength or wavelength offset can also be set in the panel

Wavelength You can select to control the wavelength either by inputting an offset or entering the wavelength directly. Use the Wavelength drop-down menu on the left as shown in [Figure 41](#) to enter select the wavelength control desired. Use either the slider or the text input box on the right of the slider to enter a wavelength or offset from the center frequency.

Figure 41 Wavelength controls

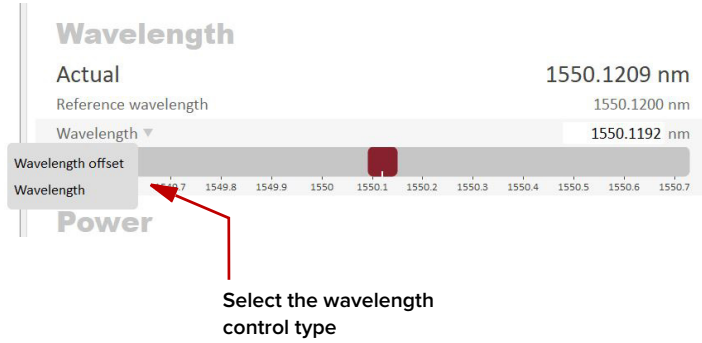

Power mode In the Power operating mode the optical output power level is used to control the laser’s output. The panel provides both a wavelength or its offset control in nanometers (or picometers for the offset) and an output power control that can be scaled in either mW or dBm.

Figure 42 Operating mode set to power

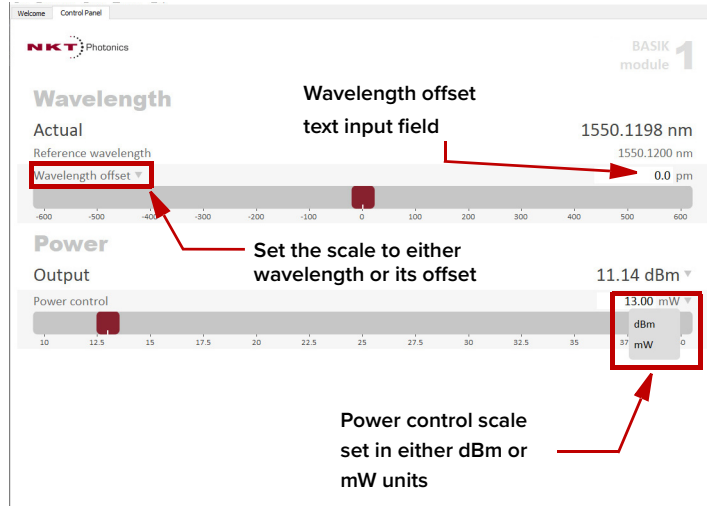

Current mode In the Current operating mode the current in the fiber pump is kept at a constant level. Only the wavelength (or its offset) control is available in the control panel menu.

Operating Mode set to Power

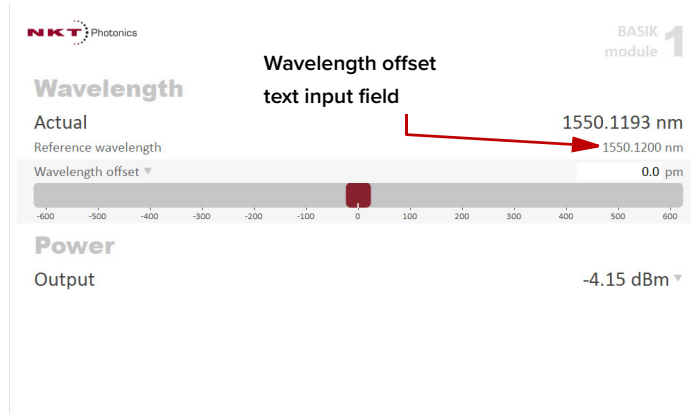

Device Monitor

The device monitor provides a live display of transmit and receive parameters of the laser's communication ports and any connected device modules.

The display parameter values are continuously updated and can be used to help debug communication issues with connected devices. The parameters are described in [Table 10](#).

Table 10 Device Monitor parameters

Parameter	Description
Interface	The PC port interface the device(s) is connected to. Click the “greater than” symbol to the left of the port to display the connected device(s) parameters.
TxTlgsSec	The number of telegrams per second being transmitted to the connected device.
RxTlgsSec	The number of telegrams received per second from the connected device.
Addr	The address of the connected module.
Type	The type of the connected module; read from the module.
SysType	The system type, default 0 – can be used to describe system variants and is read from the module.
Name	The name of the connected device module.
P/N	The device module part number.
Mode	The mode or status of the connected module: <i>connected</i> , <i>disconnected</i> , or <i>disabled</i> .
Status bits	The actual status bits read from the connected module.
Error code	The actual error code read from the connected module.
Access	Protected/Locked status of the module.
FW Ver.	The device module's firmware release date.
Module Serial	The serial number of the device module.
PCB Serial	The device module's printed circuit board serial number.
PCB Ver,	The version of the device module's printed circuit board.
Sp. Cap/	The module speed capability in bits per second as read from the module – values: 0=(default) 115200, 1=230400, 2=460800, 3=921600
Pri Ext	Primary extension/GUI loaded for this module. Hover over the icon to list more details – Note that there can only be 1 primary.
Fast Log	0%-100% collected. Note only if the module has a fast log and only internal modules have fast and slow logs.
Slow Log	0%-100% collected. Note only if the module has a slow log.
Mainboard Log	0%-100% collected. Note only if the module has a main log. Only main boards have main and system logs.
System Log	0%-100% collected. Note only if the module has a system log. Only main boards have main and system logs.
Timeout	Time in milliseconds since the last telegram was received from the device module.
Nack	Total number of negative acknowledgments received from the device module.
CRC	Total number of received telegrams with CRC failures.

Parameter	Description
COM	Total number of communication errors with framing or protocol errors. Hover over the icon to list more details.
Busy	Total number of busy responses from the module. Busy responses occur when a module receives a message but cannot process it due to its current work load.

Application log

In addition to the Serial Monitor, the Application Log panel is used for debugging serial communications. The panel displays time stamps for both COM port open and close times and also general status information. You can clear, save and print the log data using the buttons in the upper left corner.

Figure 43 Serial Monitor

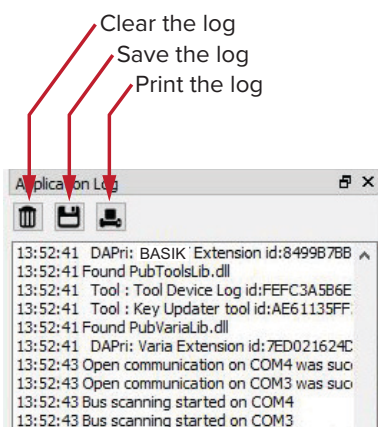

The panel is enabled by placing a check mark on the Window pull down menu next to the Application Log item.

To close the panel click on the upper right corner "X".

When testing a custom platform using the Software Development Kit, you can test registers controlling the laser's operating parameters using its Generic User Interface. For general operation it is recommended to use CONTROL. The examples in this section are to help illustrate how to use the Generic User Interface to test setting the laser's operating parameters. [Table 11](#) presents the registers by their function with a link to a detailed description.

Table 11 Generic user interface registers

Function	Register	Bit#	Unit	Description Link
Wavelength tuning	0x2A	N/A	picometers	Tuning the wavelength on page 80
Operating mode selection - toggle	0x31	8	hex	Setting the operating mode on page 80
Enabling Auto-start - toggle	0x31	10	hex	Auto start on page 80
Emission delay control	0x3A	N/A	seconds	Setting the emission delay on page 81
Narrow and wide range – toggle	0x31	1	hex	Narrow and wide range setting on page 81
Wavelength modulation signal source – external and/or internal generator.	0x31	2, 4	hex	Setting the wavelength modulation source on page 82
Function generator frequency	0xB8	N/A	Hz (32 bit)	Internal generator frequency on page 84
Function generator amplitude	0x2B	N/A	percent	Internal generator amplitude on page 84
Function generator waveform type	0xB7	N/A	hex	Internal generator signal waveform on page 84
Function generator - outputting the signal	0x31	5	hex	Internal generator -signal output on page 85
Wavelength modulation - global enable	0xB5	N/A	0 or 1	Wavelength modulation on/off on page 86
Trigger pin signal direction - input or output	0XB4	1	hex	Trigger setting input/output on page 86
Trigger signal indicating or initiating emission	0xB4	4	hex	Trigger indicates emission on page 87
Trigger set to sawtooth wavelength modulation	0xB4	2	hex	Trigger sawtooth wavelength modulation on page 87



Note: For a full description of the SDK, registers and the Generic User Interface, refer to the NKT Photonics document: *SDK Instruction Manual*. The manual is installed when the SDK installer is run.

Read/write registers

Tuning the wavelength The relationship between temperature and the fiber laser’s wavelength is stored in the laser’s memory module. To tune the laser thermally, you can write an offset wavelength (from the nominal wavelength) into register 0x2A of the memory module.

Figure 44 Setting the wavelength offset

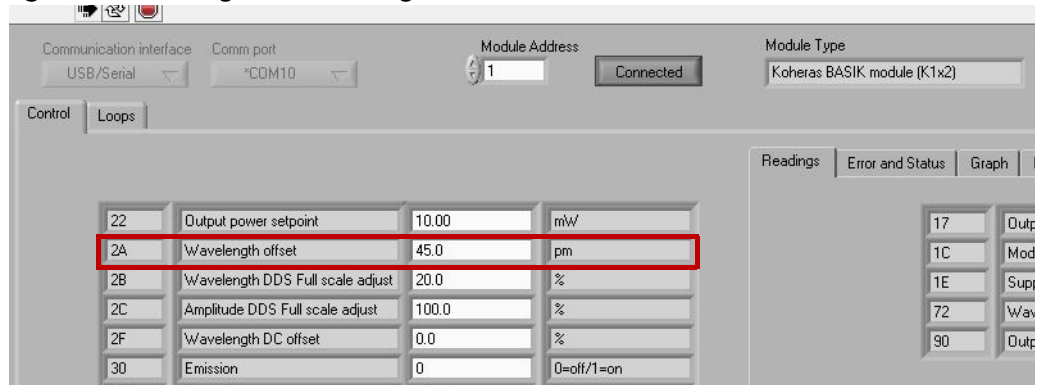

Input the wavelength offset in picometers into the register field and then press enter. Contact NKT Photonics support for more information regarding the range settable.

Setting the operating mode To set the “Power/Current mode”, modify bit 8 of register 0x31. When the bit is set to ‘0’ power mode is selected and when set to ‘1’, current mode is selected. Figure 45 shows the register with the bit set to 0, meaning the laser is set to power mode.

Figure 45 Setting the operating mode

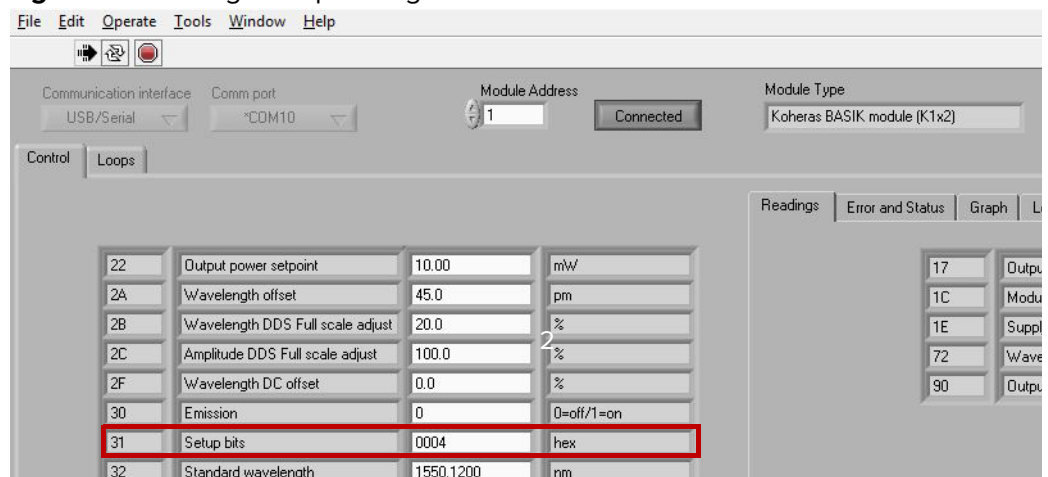

Auto start The “Auto-start” function is controlled by bit 10 of register 0x31 to enable or disable the Auto-start function. When the bit is set to ‘0’, Auto-start is disabled and when set to 1, Auto-start to enabled’.

Figure 46 Setting the Auto-start function

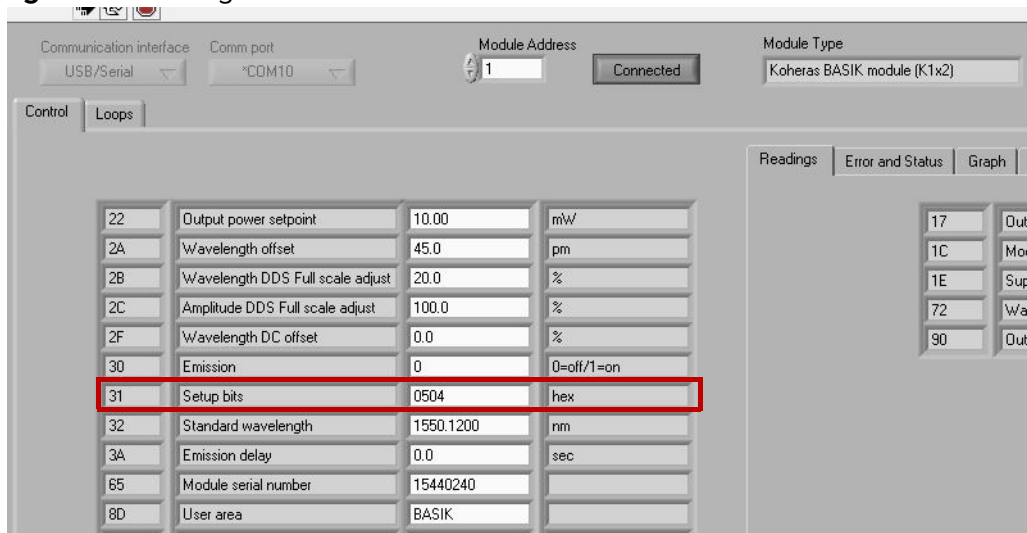

Setting the emission delay To set the emission delay timer use register 0x3A. Input the time in seconds and tenths of seconds into the register.

Figure 47 Setting the emission delay

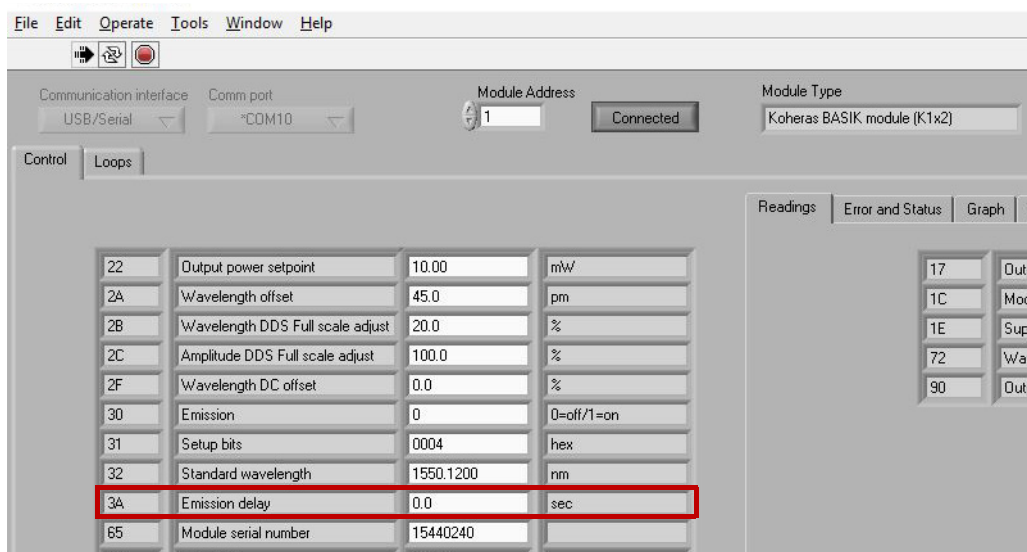

Narrow and wide range setting To configure the “Modulation range” setting to Wide or Narrow, set bit 1 of register 0x31, where ‘0’ sets the laser to operate in Wide range and ‘1’ sets the laser to operate in Narrow range. In the example shown in Figure 48, bit 1 is set as 1.

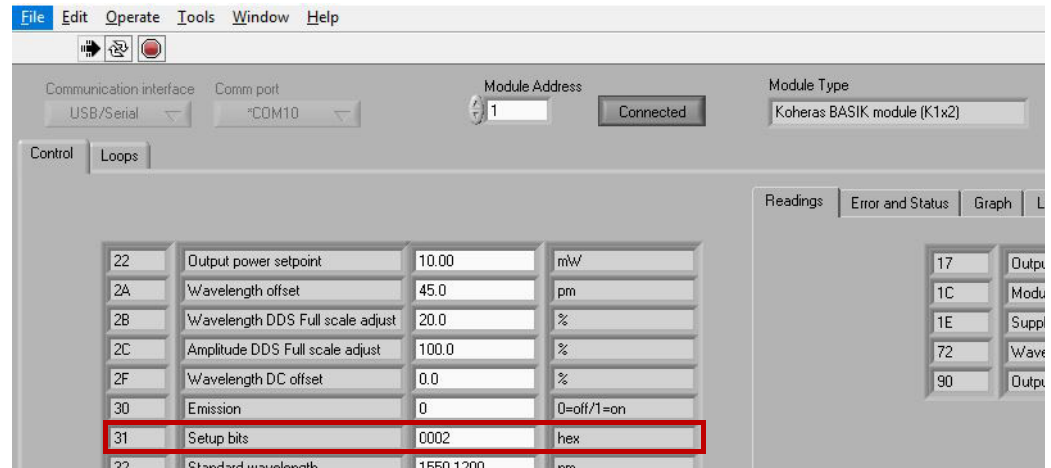
Figure 48 Setting the modulation range parameter

Setting the wavelength modulation source

To configure the “Modulation source” for the wavelength modulation option, set the following bits of register 0x31:

- Bit 2 – sets external wavelength modulation where: 0 disabled/1 enabled.
- Bit 4 – sets internal wavelength modulation where: 0 disabled/1 enabled.

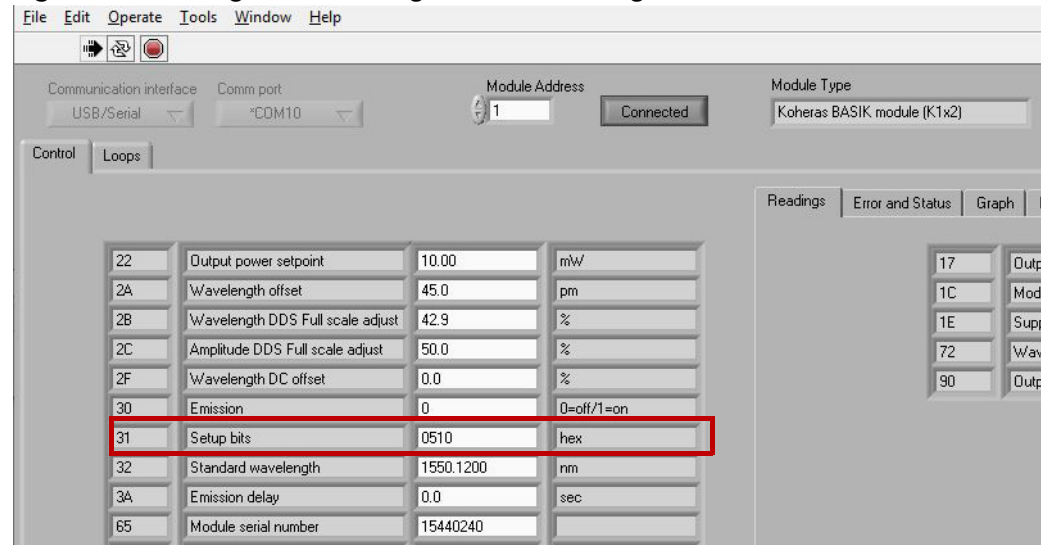
Figure 49 Setting the wavelength modulation signal source

The laser supports three different signal source combinations to modulate the wavelength. Below are some example 0x31 register settings for all three source settings.

- External
 - 0x31 set to 0504 – external source - wide range
 - 0x31 set to 0506 – external source - narrow range
- Internal
 - 0x31 set to 0510 – internal (generator) source - wide range

- 0x31 set to 0512 – internal (generator) source - narrow range
- Both
 - 0x31 set to 0514 – both (internal & external) - wide range
 - 0x31 set to 0516 – both (internal & external) - narrow range

Note: In this example, only the hex digits in the rightmost two digit positions are modified since bits 2 and 4 are in the first 8 bits of the 16 bit register.

Setting the wavelength modulation signal coupling

To configure the signal coupling for the wavelength modulation option, set bit 3 of register 0x31. Setting the bit to 0 configures wavelength modulation to use AC coupling and setting it to 1 configures it to use DC coupling.

Figure 50 Setting the coupling type

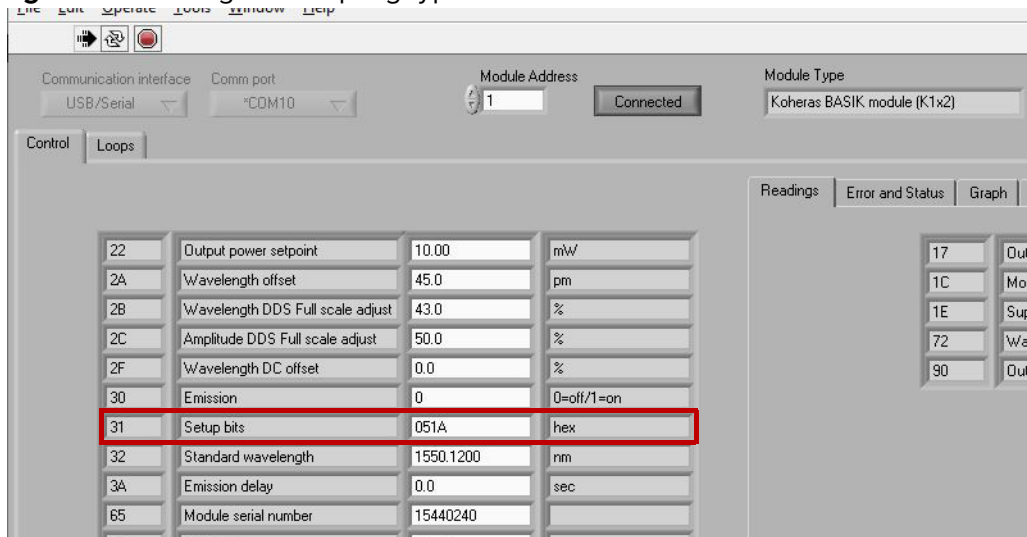

Internal generator frequency The internal function generator frequency is set with register 0xB8.0. The value is set with a 32-bit float value in hertz with a range from 0.008 to 100,000 Hz.

Figure 51 Setting the internal generator frequency

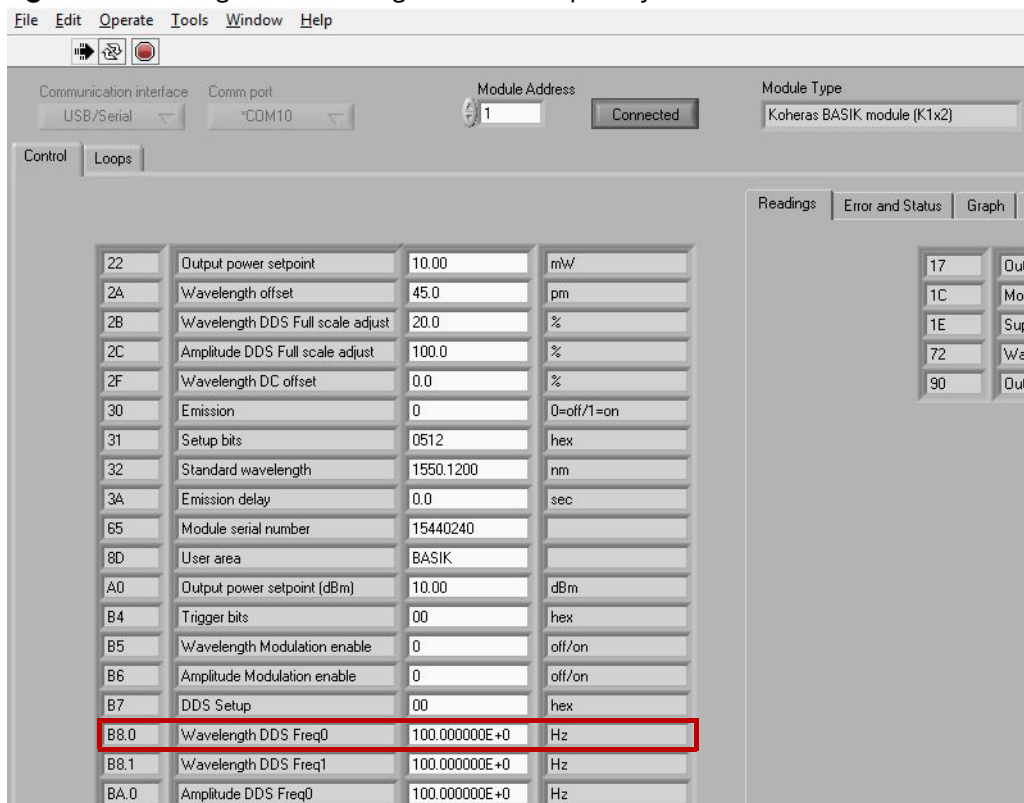

Internal generator amplitude The amplitude of the internal function generator signal is set with register 0x2B. The register is a 16-bit integer you can set from 0 to 100.0%. In the example shown in Figure 52, the signal is set to 20% of the maximum.

Figure 52 Setting the signal amplitude of the internal generator

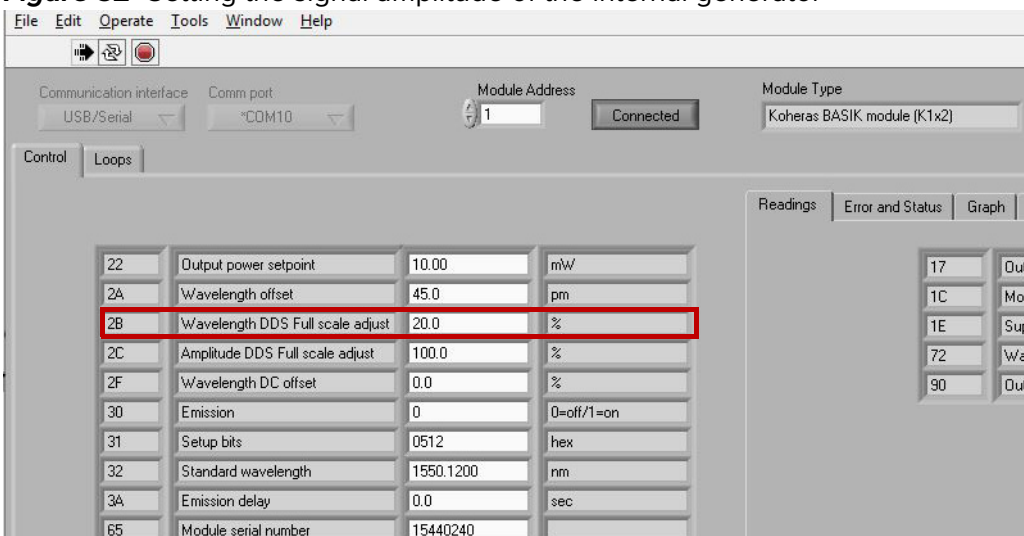

Internal generator signal waveform To change the output waveform, set register 0xB7. To configure a waveform, Set the values as follows:

- 01 – sinusoidal
- 41 - triangular
- 81 – sawtooth
- C1 – inverse sawtooth

Figure 53 Setting the internal generator waveform

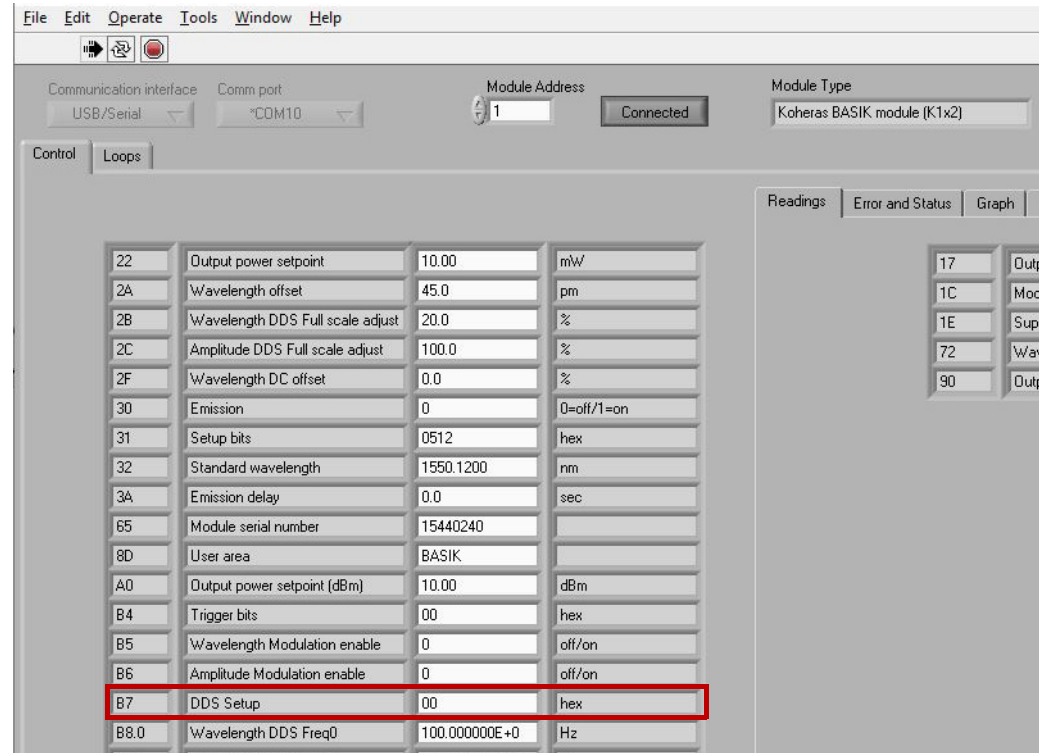

Internal generator - signal output To enable or disable outputting the internal generator signal on the *Wavelength +/-* pins, set bit 5 of register 0x31, where setting the bit to '0' disables the signal generator output and '1' enables signal generator output.

Figure 54 Toggling the internal generator signal output

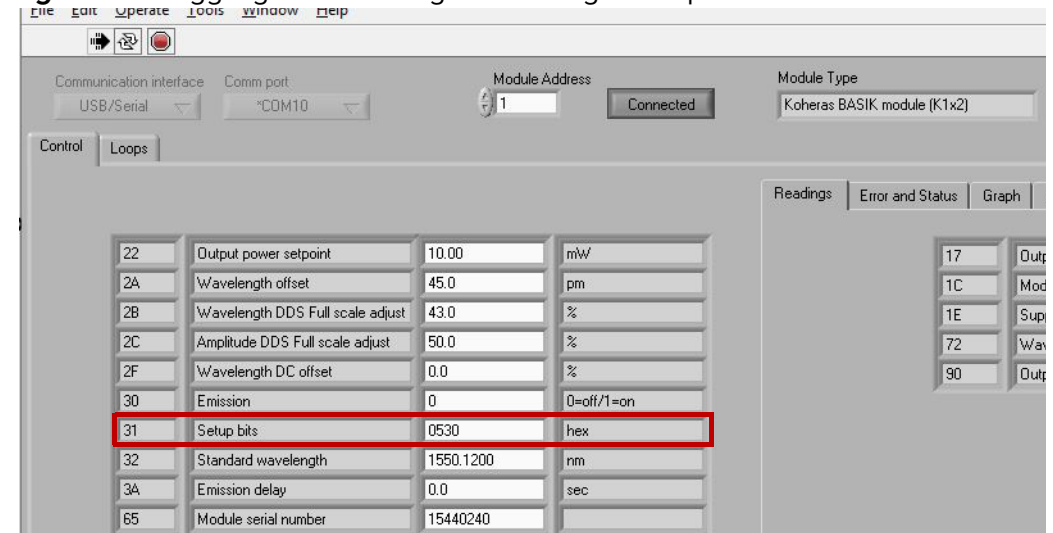

Wavelength modulation on/off To enable wavelength modulation set register 0xB5, where '0' means 'OFF' and '1' means 'ON'.

Figure 55 Turning ON wavelength modulation

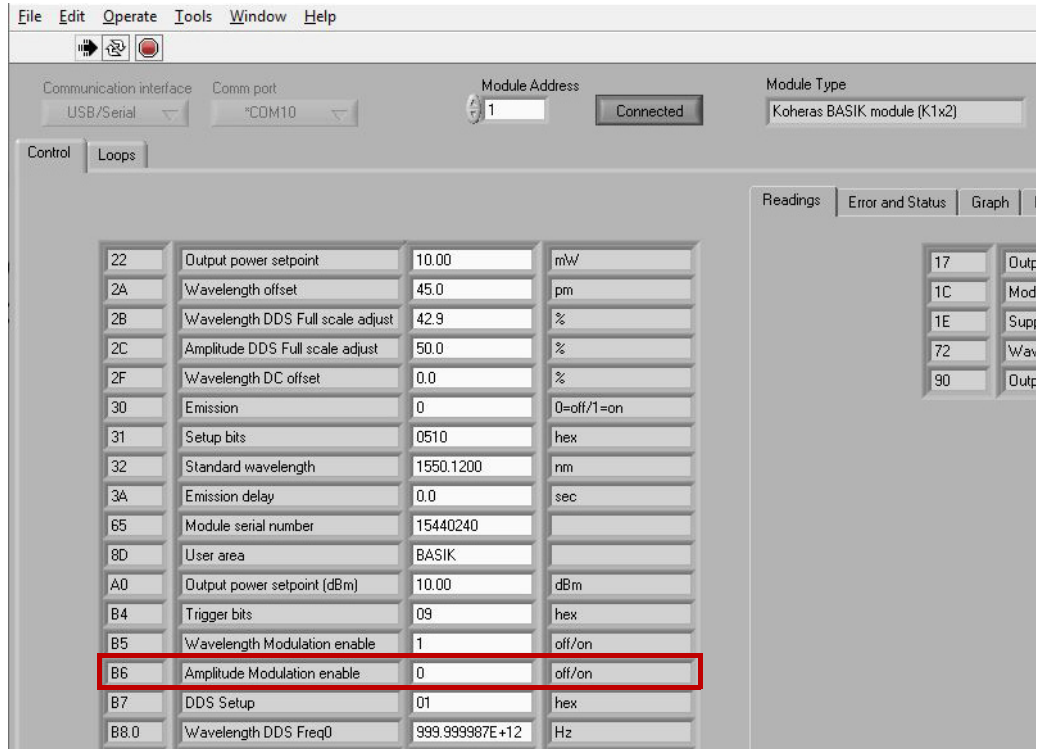

Trigger setting input/output To configure the Trigger signal pin as an input or output, set register 0xB4 bit 1, where '0' means input and '1' means output. Figure 57 shows an example of the trigger pin set as an output.

Figure 56 Setting the trigger to input or output

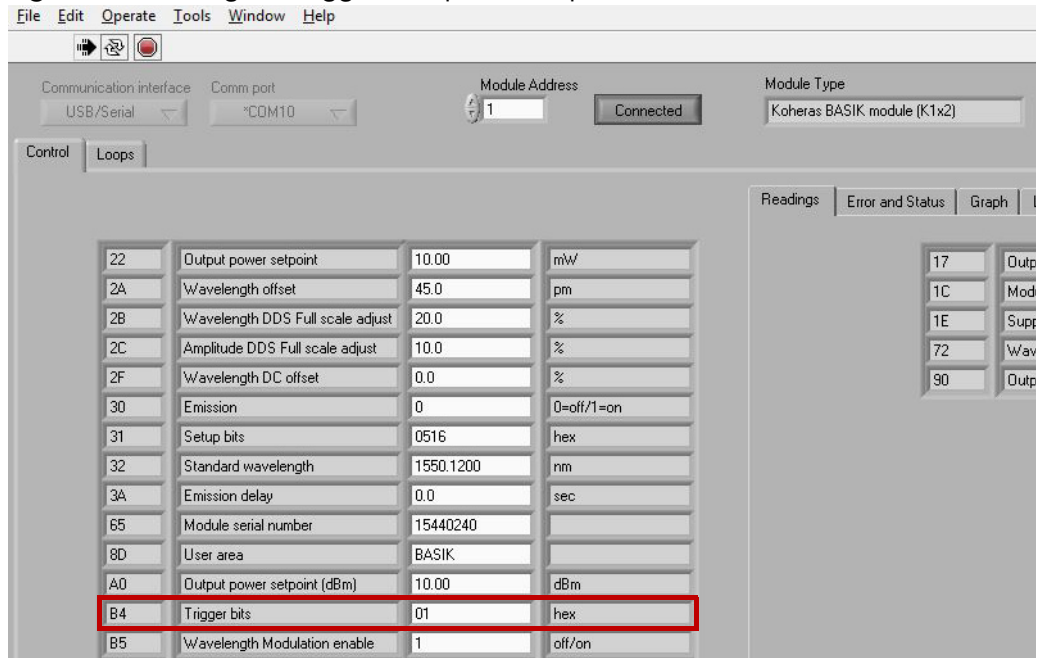

Trigger indicates emission To configure the trigger signal to indicate laser emission is enabled set bit 4 of register 0xB4, where '1' means 'Emission' and '0' means OFF which results in no signal being sent even if the laser emission is enabled.

Note: Bit 4 cannot be set simultaneously with bit 2 of register 0xB4.

Figure 57 Trigger set to indicate emission

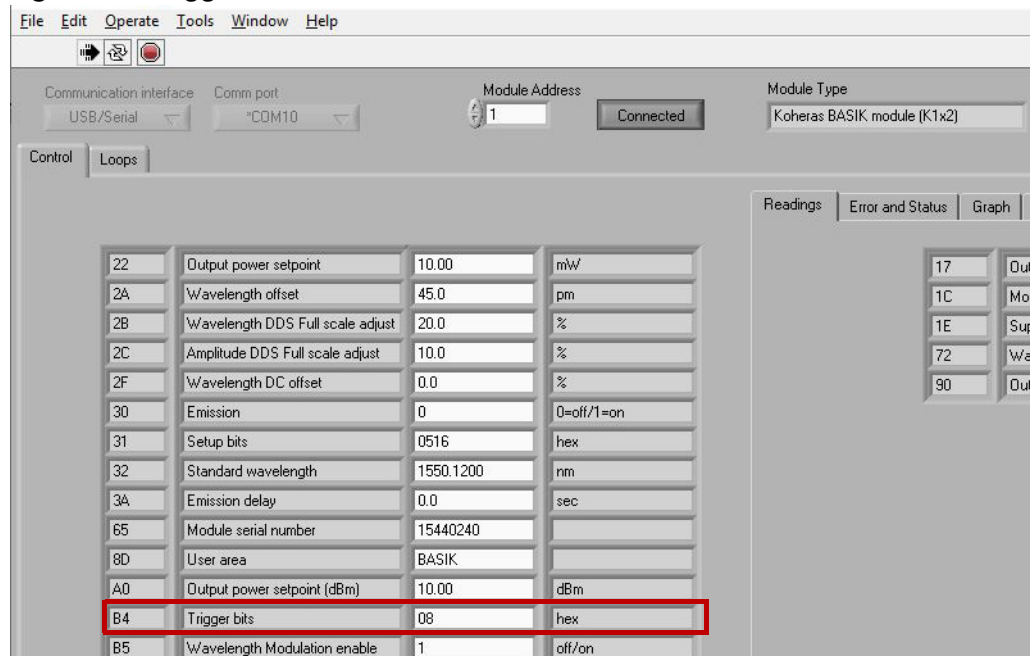

Trigger sawtooth wavelength modulation To configure the trigger for sawtooth wavelength modulation, set bit 2 of register 0xB4, where '1' means 'Sawtooth wavelength modulation' and '0' means OFF.

Note: Bit 2 cannot be set simultaneously with bit 4 of register 0xB4.

Figure 58 Trigger set to sawtooth wavelength modulation

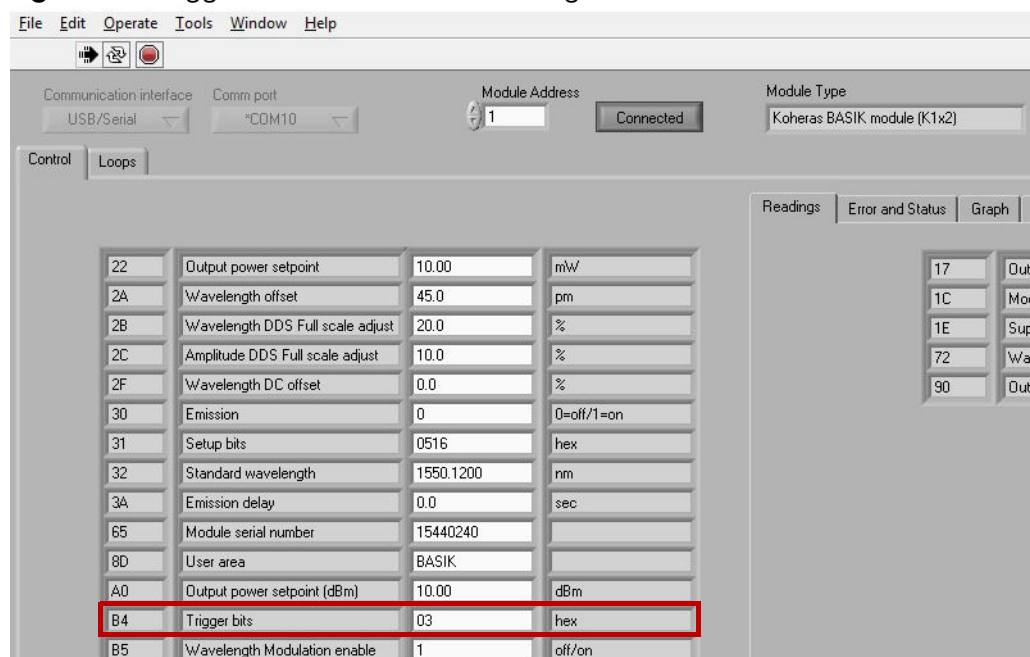

Readings

For each module, click on the *Readings* tab to view the contents of read-only registers. Of particular interest are registers 17 and 90. When laser emission is enabled, the output power in mW and dBm is displayed in these registers respectively.

Figure 59 Read-only registers under the *Readings* tab

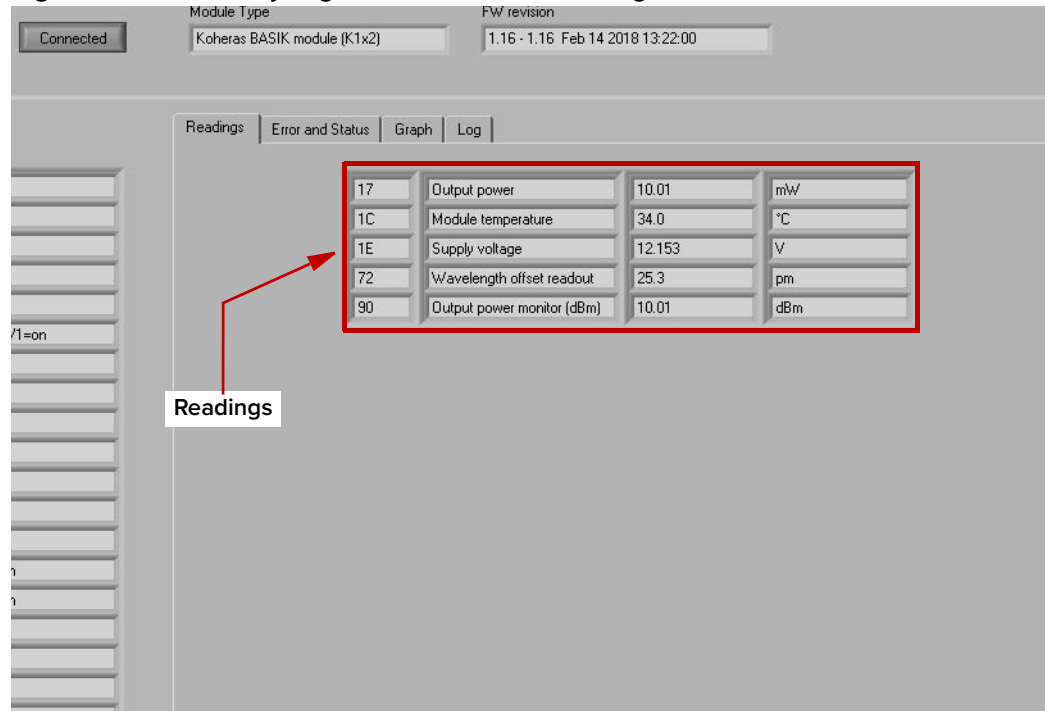

The screenshot shows a software interface with a 'Readings' tab selected. The interface displays a table of read-only registers. A red box highlights the registers 17, 1C, 1E, 72, and 90. A red arrow points from a 'Readings' label to the highlighted table.

Register	Parameter	Value	Unit
17	Output power	10.01	mW
1C	Module temperature	34.0	°C
1E	Supply voltage	12.153	V
72	Wavelength offset readout	25.3	pm
90	Output power monitor (dBm)	10.01	dBm

Errors and status indicators

For each module, click on the *Error and Status* tab to view the status indicators and if any error codes are displayed.

Status indicators The status indicators will be lit green if the condition in the text is true.

Error codes If an error code is displayed and cannot be cleared contact NKT Photonics support, see [“Support contact details”](#) on page 112.

Figure 60 Error and status tab

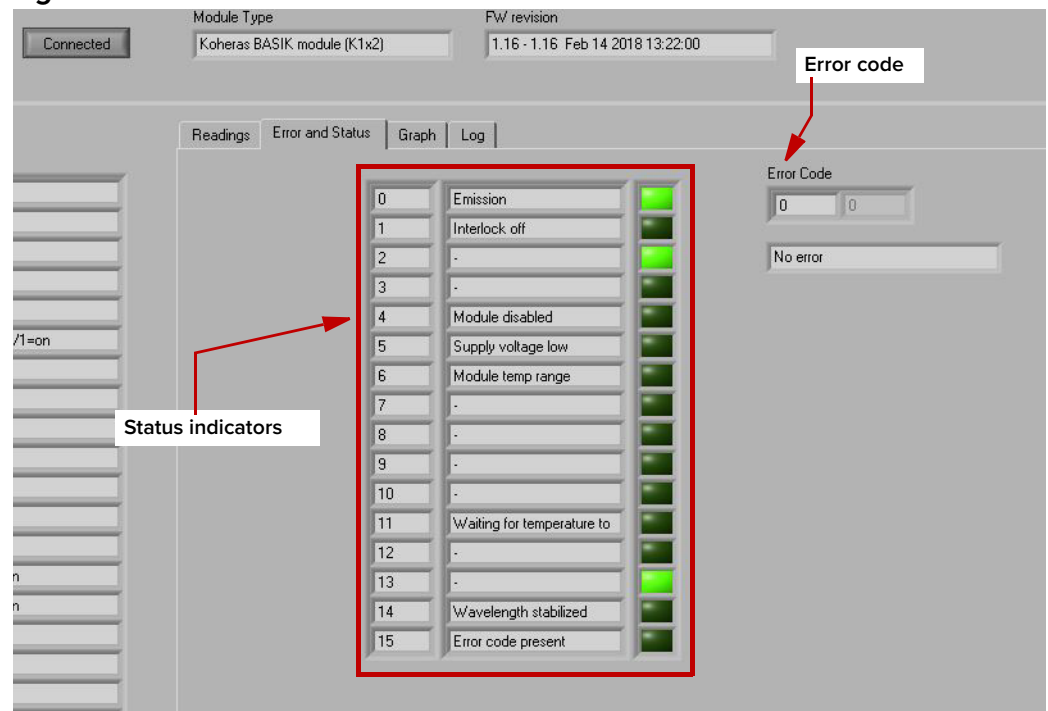

Graphing

As shown in [Figure 61](#), you can graph the values of selected parameters by clicking on the Graph tab and selecting the parameter you want to graph. To use the graphing function:

1. Select the parameters to graph from the drop-down menu at the left/right y-axis and bottom x-axis of the graph.
2. Modify the left/right y-axis and x-axis maximum range with the input boxes.
3. Set the sample number and rate using the input boxes to the left of the graph.

SECTION 3

INSTALLING THE LASER

This section describes how to install the laser and includes the chapters:

- “Mechanical Installation” on page 93
- “Connecting the Laser” on page 97

The laser module is designed to operate as either a stand-alone module installed on a flat surface or as a sub-module where a single module or multiple modules are inserted into a shelf or other appropriate receptacle. The laser generates heat that must be dissipated. This section describes how to mount the laser module to ensure optimal function and heat dissipation.

General

All chassis types must be installed on a level surface that is free from vibrations. The ambient temperature surrounding the laser should be stable and free from anything that could cause temperature fluctuations. Temperature changes and vibrations may affect the laser's operation and result in abnormal operation.



Caution: For reliable operation, the laser should not be exposed to corrosive agents or excessive moisture, heat sources or dust.

Standalone mounting

Heat dissipation The heat generating components within the module are thermally connected to a 50 by 20 mm area shown in [Figure 62](#) on the rear panel next to the electrical interface. When operating the laser under extreme conditions, mount a heat sink onto this area. For normal office and laboratory operation, a heat sink is unnecessary.

Figure 62 Heat transfer surface - BASIK rear panel

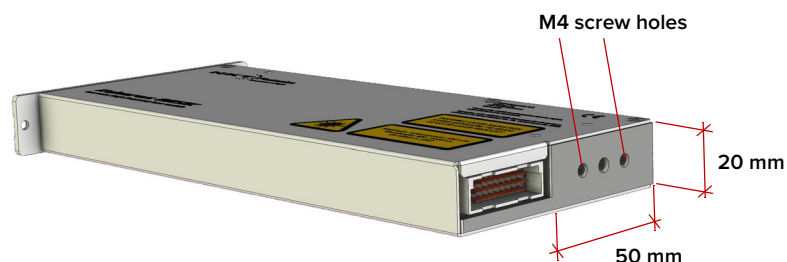

Heat sink mounting

To mount a heat sink, use the two M4 screw holes on the rear panel ([Figure 62](#)) to fix the heat sink and ensure there is thermal contact with the module.



Caution: When using the rear panel M4 screw holes, do not turn the fastening screws more than a maximum of 10 mm into the laser chassis.

Thermal resistance

Thermal resistance (R_{θ}) to the environment depends on the maximum environmental temperature. The maximum module temperature and maximum power consumption for the module is calculated as follows:

$$R_{\theta} = (t_{\text{module}} - t_{\text{environment}}) / P_{\text{max}}$$

Where:

$$t_{\text{module}} = 60 \text{ }^{\circ}\text{C}$$

$$P_{\text{max}} = 12 \text{ watts.}$$

Mounting the laser

You can fasten the laser to a table or other mounting surface using machine screws. Insert the screws through the laser's three 3 mm mounting holes as shown in [Figure 63](#).

Figure 63 Heat transfer surface - BASIK rear panel

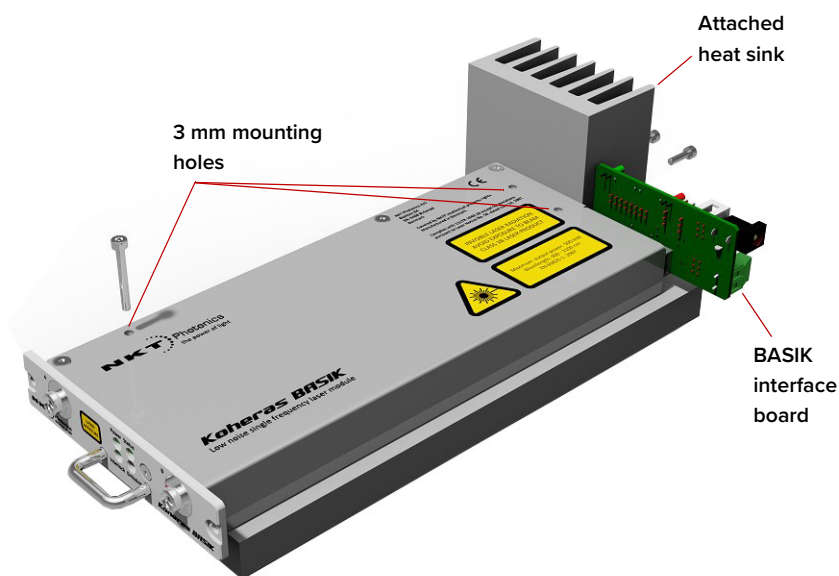

Note: For exact dimensions of the laser and its mounting holes refer to [Figure 71](#). When designing your installation, ensure to allow for a heat sink and the BASIK interface board should one or both be employed.

Slide-in mounting

The laser module can be installed in a custom shelf or receptacle where it is designed to slide into suitable rails or a receptacle. The mount must accommodate the dimensions of the laser (see [Figure 71](#)) so it is held firmly, heat is dissipated from the rear panel surface and the electrical connection aligns and connects with the rear panel 16 pin IDC connector.

Heat dissipation

Ensure that when the laser is inserted, the rear heat dissipation area (see [“Heat dissipation” on page 93](#)) makes contact with a suitable surface that can conduct heat away from the laser.

Aligning the main electrical interface

[Figure 63](#) shows a 3.3 mm alignment hole with a depth of 8 mm available in the center of the heat transfer surface. The hole is designed to mate with an alignment pin on the back panel of a module mounting rail or receptacle system. The pin helps ensure the 30-Pin DIN C/3 electrical interface (see [“Main electrical Interface” on page 26](#)) mates properly and it relieves potential mechanical stress from the connector.



Note: Detailed dimensions are shown in [Figure 71](#).

Figure 64 Mounting the laser

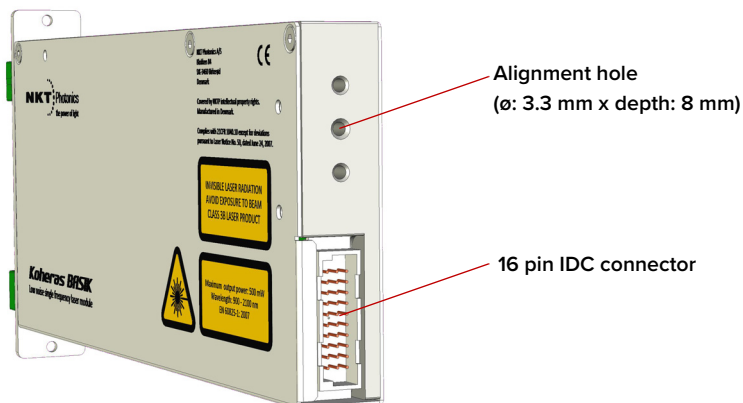

Front panel

When using a slide-in type mount, the front panel is equipped with both a handle and two front panel mounting holes as shown in [Figure 65](#). Use the handle when sliding the laser in and out of its mount. Once installed in a rail or receptacle mount, fix the laser in place, using two screws to fasten the front panel to its mounting fixture.

Figure 65 Front panel mounting holes and handle

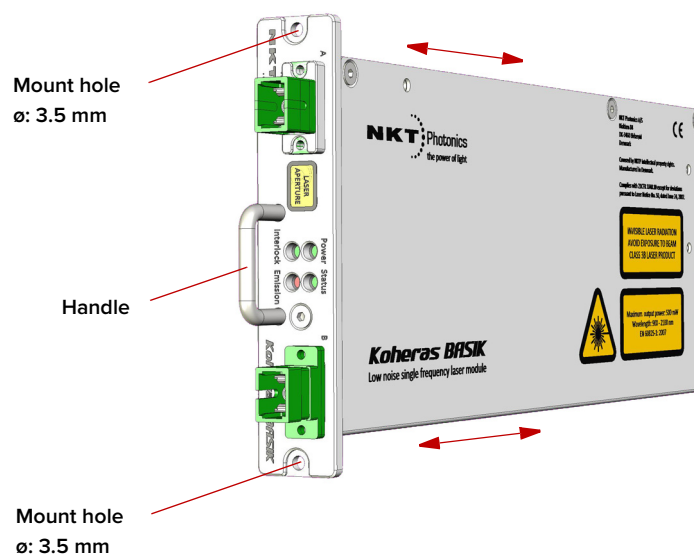

Operating and storage environment

[Appendix A](#) details the required ambient operating and storage environment specifications.



Warning: The Koheras BASIK is a Class 3B laser product and its operation facility and conditions must comply with the standards listed below or similar:

- CFR21 1040.10 & Laser Notice LN50
- IEC / EN 60825-1

Before operating the laser, follow the procedures in this chapter to ensure its correct and safe operation.

For information on how to connect:

- The safety interlock – see [“Connecting the safety interlock” on page 97](#)
- Power – see [“Connecting power” on page 99](#)
- Modulation signal inputs and outputs – see [“Connecting modulation signals” on page 99](#)
- Trigger – see [“Connecting the trigger input or output” on page 102](#)
- The optical output – see [“Connecting the optical output” on page 103](#)

Connecting the safety interlock

To comply with safety regulations and help provide a safe operating environment, connect the laser’s safety interlock to a switch activated by an access door to the laser’s enclosure. When the switch connected to the operating area access door opens, it opens the interlock circuit which immediately disables laser emission. To enable emission again, the circuit must first be closed, the interlock reset and the emission button clicked to ON in CONTROL.

Interlock operation Pin 5 of the Main Interface 16 pin connector supplies a positive voltage signal. When this signal is connected to Pins 7 and 18 through a closed door switch, laser emissions are enabled. If the door switch opens, the potential at pins 7 and 8 drops to zero volts and the laser’s electronic logic shuts down the laser.

Lemo connector The RS-485 adapter includes a 2 pin LEMO connector to connect a door switch cable using LEMO connector FGG.0B.302. The ribbon cable between the laser and the RS-485 USB adapter connects the 2 pins of the LEMO connector to the main interface connector.

Figure 66 Safety interlock connected to a door switch (open position)

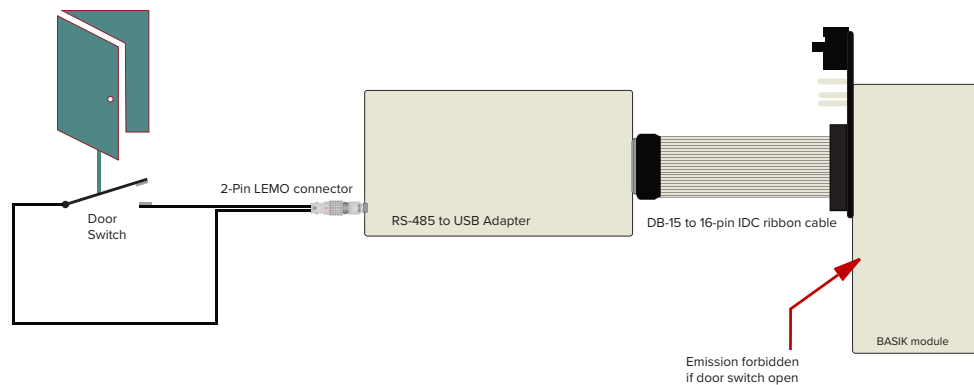

Caution: Do not short-circuit the interlock input. Short-circuiting the interlock circumvents safety regulations and NKT Photonics does not take liability for any injuries or damage caused by doing so.



Caution: The switch connected to the interlock must be of an approved type. Further, the switch must be installed in a manner so that its operation cannot be fixed in the open state using a tool.



Warning: If the interlock is bypassed using the interlock defeater, personnel may be exposed to hazardous laser radiation. To reduce the risk to personnel, the person or group responsible for operation of the equipment must undertake a risk assessment and provide personnel with appropriate personal protective equipment and safety training.

Connecting an interlock switch

Follow the steps in [Procedure 8](#) to connect a safety door switch to the interlock circuit of the laser.

Procedure 8 Connecting the door interlock circuit (with the RS-485 adapter)

Action	
1	Install a switch that opens when the door accessing the laser enclosure is opened. The switch must comply with safety regulations.
2	Using a cable with a maximum wire length of five meters and at a minimum 26 AWG, connect the switch to a LEMO connector. For cable lengths longer than five meters, it is recommended to use shielded cable.
3	Perform a continuity test using a multimeter: <ul style="list-style-type: none"> • First connect the multimeter leads to the interlock plug terminals. • Confirm when the enclosure door is closed, the meter shows the circuit as closed. • Confirm when the enclosure door opens, the meter shows the circuit as open.
4	Using the DB-15 to IDC 16 pin ribbon cable, connect the RS-485 to USB adapter to the laser (via the BASIK interface board).
5	Insert the LEMO connector into the LEMO interlock connector of the RS-485 adapter.

Connecting power

The RS-485 adapter kit includes an external power supply shown in [Figure 67](#). The power supply connects 12 volts DC output to the RS-485 adapter by means of a two pole barrel connector. Power is delivered to the laser through the ribbon cable from the adapter to the laser's 16 pin main interface connector (via the BASIK interface board). Refer to [Table 20 on page 113](#) for the laser's pin assignments.

Follow the instructions in [Procedure 1](#) to connect power to the laser using the RS-485 adapter.

Figure 67 Power supply



Table 12 Power adapter specifications

Item	Description
DC Output	12 V – 5 A
AC Input	100-240 VAC @ 50-60 Hz – 1.5 to 0.7 A
AC Connector (inlet)	IEC 60320 – C6
DC Connector	2.5 mm Barrel (2.5x5.5x12)

Connecting modulation signals

Input and output wavelength modulation signals are described in chapter 2: “[Modulation](#)”. The signals are connected to or available from the pins on the rear panel C/3 DIN connector, see “[Main electrical interface](#)” on page 113. Alternatively if you are using the BASIK interface board refer to the following section: [BASIK interface board](#).

BASIK interface board The BASIK interface board shown in [Figure 68](#), provides a convenient method to connect an external PC and other signals to the various PIN connectors on the main electrical interface connector.

Figure 68 BASIK interface board

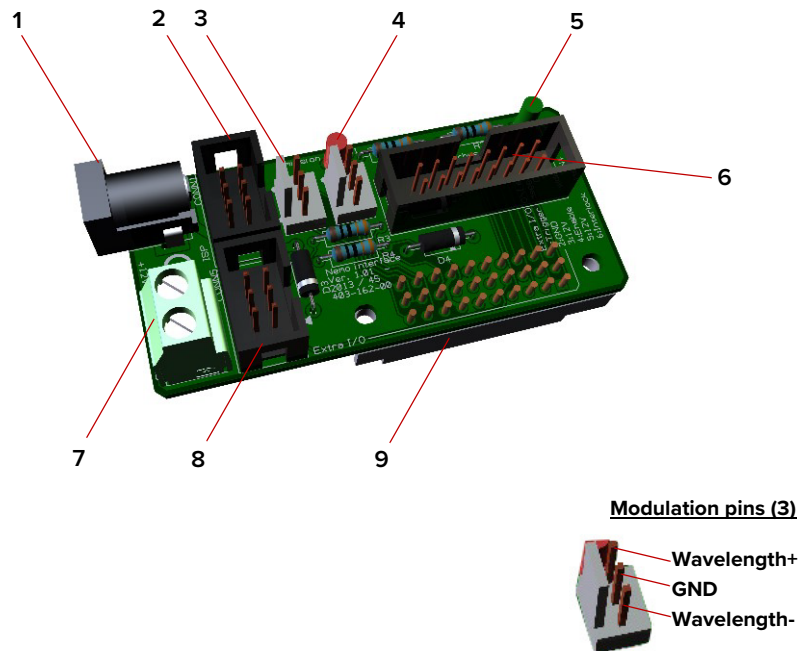

- | | |
|---------------------------------------|-------------------------|
| 1. DC input connector | 6. Interbus |
| 2. ISP | 7. 2-pin screw terminal |
| 3. Wavelength modulation input/output | 8. Extra I/O |
| 4. Emission indicator LED | 9. DIN 41612 female C/3 |
| 5. LED | |

i **Note:** If desired, the Koheras BASIK can connect directly to a system main board if it supports a DIN 41612 female C/3 connector.

DC Input Connector

As an alternative to the 2-pin screw terminal, the module can be connected to 12 volts DC using the 2.1 mm barrel type DC input connector. Connect 12 VDC to the center pin and ground to the outer ring of the barrel connector.

ISP

The In-Serial-Programming 6-pin IDC connector is only for factory use – do not connect.

Wavelength modulation input/output

The interface board includes a 3 pin Molex 2.54 mm KK-connector to connect wavelength modulation input or output signals – see Modulation pins in [Figure 68](#).

Table 13 Wavelength modulation pin descriptions

Pin	Name	Description
1	Wavelength+	Positive branch of differential input/output for wavelength modulation.
2	AGND	Analog ground for wavelength modulation signals
3	Wavelength-	Negative branch of differential input/output for wavelength modulation.

Emission indicator LED

The emission indicator LED turns ON red when the laser emission is enabled.

Power indicator LED

The power LED turns ON green when a 12 volt DC supply is connected to the module.

Interbus

Connects to the USB-RS-485 adapter over a ribbon cable to control the laser directly from a PC. The connector additionally carries interlock, enable and power signals to and from the RS-485 adapter. See [“Connecting CONTROL to the laser” on page 50](#).

2-Pin Screw Terminal

Connect a 12 VDC power supply to these two screw terminals to operate the module in stand-alone mode.

To obtain laser emission automatically when power is connected to the laser, the Interlock and Enable pins of the Extra I/O connector must be pulled-up and the Auto-start control bit must be set – see [“Auto-start” on page 29](#).

Extra I/O

This 6-pin IDC connector provides miscellaneous connections. Use these for example, to pull-up Enable and Interlock signals when the module is installed without the Interbus interface.

Table 14 Extra I/O pin descriptions

Pin	Name	Description
1	Trigger	Logic input/output. Requires external pull-up resistor when used as an output.
2	GND	0 volt / ground
3	12V	12 V – the interface board contains a 10 kΩ resistor in series with pin B7.
4	Enable	This logic input is set high to enable laser emission. When emission is enabled and this pin is set low, emission is shut off. A 10 kΩ resistor on the Interface board pulls the Enable pin of the Extra I/O connector to 12V. Place a jumper across pins 3 and 4 to pull Enable high if the module is used without an Interbus interface.
5	12V	12 volts – the Interface board contains a 10kΩ resistor in series with pin B8.
6	Interlock	This logic input is set high to enable emission. laser emission. When emission is enabled and this pin is set low, emission is shut off. This input is for personal safety, and includes redundancy inside the module. A 10 kΩ resistor on the Interface board pulls the Interlock pin of the Extra I/O connector to 12V. Place a jumper across pin 5 and pin 6 to pull Interlock high if the module is used without the Interbus interface.

DIN 41612 female C/3

The DIN 41612 female C/3 connector on the bottom panel of a BASIK interface board plugs into the main electrical interface of a BASIK module.

Connecting the trigger input or output

The modules include a trigger logic input/output signal in the electrical interface (see [Table 20](#)). The trigger signal can be used to either initiate or indicate laser emission.

i **Note:** For information on how to configure the trigger as either an input or output using CONTROL see “[Trigger](#)” on page 69. For setting the trigger direction using the SDK, see “[Trigger setting input/output](#)” on page 86.

Input trigger When set as an input a positive active high signal must be applied to the trigger pin to initiate emission. The diagram [Figure 69](#) shows the trigger input.

Figure 69 Trigger input circuit

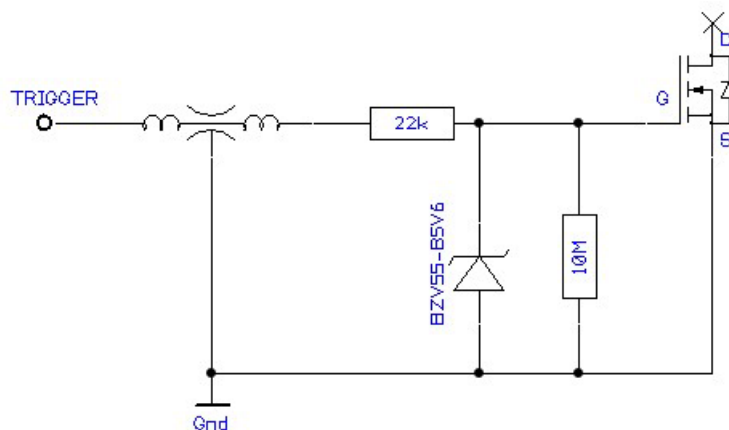

Output trigger When the trigger feature is set as an output, the trigger pin should be connected to an external pull-up resistor. The diagram [Figure 69](#) shows the trigger output circuit.

Figure 70 Trigger output circuit

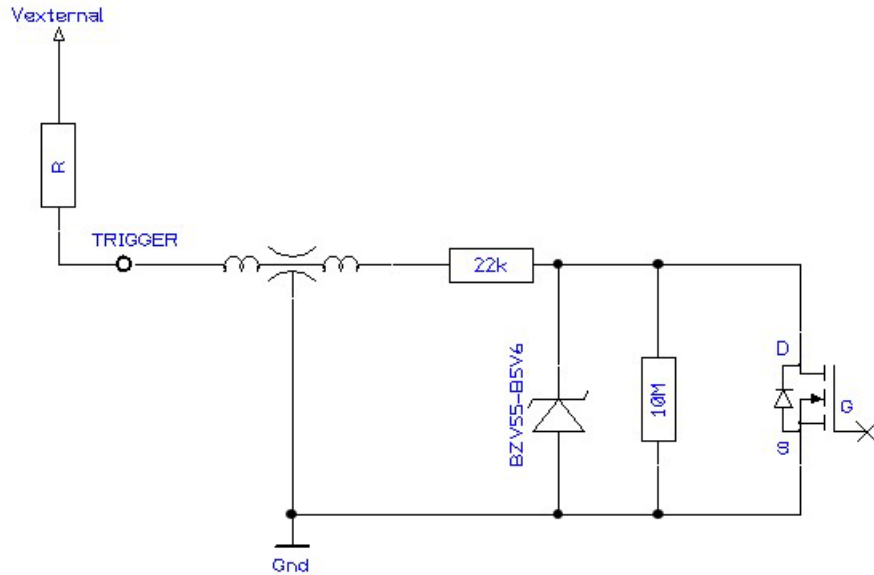

The high and low voltage levels are defined by the following equations:

$$V_{\text{high}} = V_{\text{external}}$$

$$V_{\text{low}} = V_{\text{external}} \times 22\text{k} / (22\text{k} + R)$$

Connecting the optical output

Before connecting the optical output connectors, ensure to check the connector tips using a fiber microscope. Check for any deformities, damage, residue or other contaminants at the optical tip of the connector. Either clean the connector or contact NKT Photonics support if replacement is necessary.

APPENDICES

The appendices include:

- [Appendix A on page 107](#): Specifications
- [Appendix B on page 111](#): Service and Support
- [Appendix C on page 113](#): Interface Pin Assignments
- [Appendix D on page 115](#): CONTROL Installation
- [Appendix E on page 121](#): RS-485 Adapter
- [Appendix F on page 123](#): Configuration IDs

A Specifications

Table 15 Optical

	X15	E15	C15	Y10
Laser Emission	CW - inherently single frequency			
Beam Quality (M2)	< 1.05	< 1.05	< 1.05	< 1.05
Linewidth (kHz)¹	< 0.1	< 0.1	< 15	< 20
Max. Phase Noise [dB((rad/√Hz)/m)]	-110 @ 1 Hz -125 @ 10 Hz -130 @ 100 Hz -128 @ 1 kHz	- -90 @ 10 Hz -110 @ 100 Hz -130 @ 20 kHz	- -69 @ 10 Hz -89 @ 100 Hz -109 @ 20 kHz	- - - -
Max phase-noise [μrad/√Hz/m]	3.1 @ 1 Hz 0.6 @ 10 Hz 0.3 @ 100 Hz 0.4 @ 1 kHz	- 32 @ 10 Hz 3.2 @ 100 Hz 0.3 @ 20 kHz	- 355 @ 10 Hz 36 @ 100 Hz 3.5 @ 20 kHz	- - - -
Peak RIN (MHz)	~ 0.7	~ 0.7	~ 1.0	~ 1.5
RIN level @ Peak / 10 MHz (dBc/Hz)	<-100 / <-135	<-100 / <-135	<-120 / <-140	<-105 / <-140
Optical S/N (50 pm res.) (dB)	> 50 (typ. > 55)	> 50 (typ. > 55)	> 65 (typ > 70)	> 65 (typ > 70)
Min. Thermal Tuning Wavelength Tuning Range (pm)²	+/- 125	+/- 350	+/- 350	+/- 240
Total thermal tuning range [pm]	350	1000	1000	680
Option Specifications				
Fast Wavelength Modulation range (GHz)	0.6	8	8	10
Fast Wavelength Modulation (KHz)	up to 20	up to 20	up to 20	up to 20
PM Output - PER (dB)	>23	>23	>23	>23

1. Lorentzian
2. Relative to the center wavelength at room temperature. If the laser case temperature is outside the range of approximately 10-50 °C, the range of detuning from the center wavelength may be reduced.

Table 16 Mechanical dimensions

All chassis models	
Size (H x W x D)	20 x 70 x 150 mm 0.79 x 2.76 x 5.91 in)
Weight	0.35 kg (0.77 lb)

Table 17 Operating and storage environment

All Chassis Models	
Operating Temperature	15°C to 60°C (59°F to 140°F)
Storage Temperature	-20°C to 60°C (-4°F to 140°F)
Operating Humidity (non-condensing)	0 to 70%

Table 18 Electrical

All Chassis Models

Supply Voltage	11 to 13 VDC 5 A
Maximum Power Consumption	10 W

Table 19 Safety and regulatory compliances

Safety	Regulatory
EN 60825-1:2014: Safety of laser products Part 1: Equipment classification and requirements [Laser Class 4]	EN 61326-1:2013: Electrical equipment for measurement, control and laboratory use EMC requirements – Part 1: General requirements 2004/108/EC Electromagnetic Compatibility
EN 61010-1:2010: Safety requirements for electrical equipment for measurement, control, and laboratory use Part 1: General requirements	2011/65/EC Restriction of the use of certain Hazardous Substances in electrical and electronic equipment (RoHS)

Figure 71 Mechanical dimensions

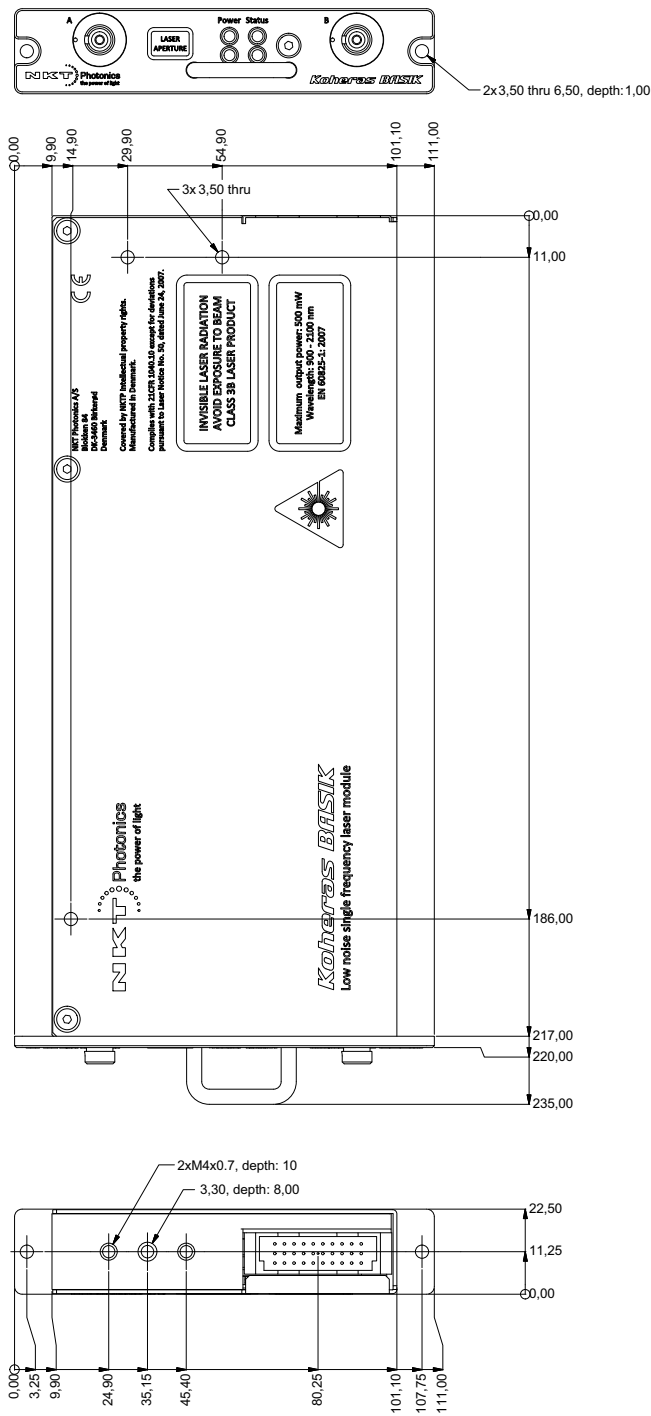

B Service and support Information

Servicing the laser

The laser have no user serviceable components. In case of malfunction, contact NKT Photonics using the support channels in section “[Support contact details](#)”.



Caution: Do not open the laser’s modules. The laser modules are equipped with warranty labels (see [Figure 72](#)) on the covers of the laser chassis. The warranty is void if the system is opened.

Figure 72 Warranty seal

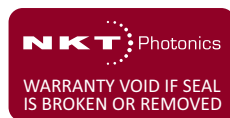

Caution: The laser contains electro-static discharge (ESD) sensitive components. To avoid permanent ESD damage, use ESD protection precautions when handling the laser. Always connect the laser’s earth point to a ground earth within your facility.

Opening the laser chassis There are no user serviceable components inside the laser chassis. Should your laser malfunction, and it cannot be serviced on site, it must be shipped to the NKT Photonics office in Birkerød, Denmark.

WARRANTY VOID IF REMOVED Label The unit is sealed with a label “WARRANTY VOID IF REMOVED”. It is strictly prohibited to remove the chassis cover

Support contact details

If you need help or have questions regarding your Koheras BASIK laser or its accessories, contact NKT Photonics through our support website below:

Support website

1. Go to:

<https://www.nktphotonics.com/lasers-fibers/support/technical-support-and-customer-service/>

2. Scroll down and click or press:

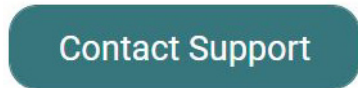

3. Select the type of help required, fill in the form, and click or press *Submit*.

Shipping address NKT Photonics A/S
Blokken 84
DK-3460 Birkerød
Denmark

C Interface Pin Assignments

Main electrical interface

The main electrical interface connector on the laser is a 30 pin DIN41612 male C/3 type. Pin numbering is shown in [Figure 73](#) and the pin assignments are described in [Table 20](#).

Figure 73 Main electrical interface PIN layout

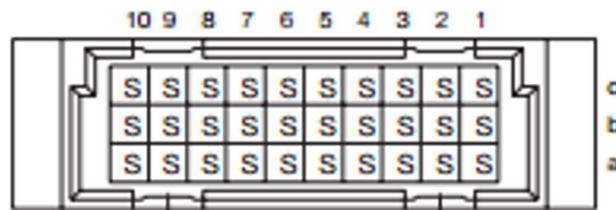

Table 20 Main electrical interface pin assignment

Pin #	Signal	Description
A1	Module OK	Low: module enable low OR module not stable (frequency tuning) High: module stable (frequency)
A2	RS485-	The negative/inverted part of the RS485 communication signal.
A9	Amplitude-	Input used to connect the negative signal of the differential input used for amplitude modulation. (not currently used)
A10	Wavelength-	Input used to connect the negative signal of the differential input used for wavelength modulation.
B1	3.3V	3.3 volt output. Only used for micro-controller programming. Do not connect.
B2	PDI	Do not connect – Program and debug interface only used for micro-controller programming.
B3	Reset	Do not connect – Reset signal input for the microprocessor.
B4	Trigger	Logic input/output. Used either as a control input or an output that indicates laser emission. An external pull-up resistor is required when used as output. As an output the signal is active high.
B9	AGND	Analog ground for amplitude and wavelength modulation signals.
B10	AGND	Analog ground for amplitude and wavelength modulation signals.
C1	Emission	Collector output with internal 240 Ω resistor in series. The output is high when the Koheras BASIK laser emission is ON. To provide an external visual indication of emission, connect the anode of an LED directly to this pin and then connect the LEDs cathode to GND.
C2	RS485	The positive/non-inverted part of the RS485 communication signal.
C3	Enable	Logic input that enables emission when a high (5V) is applied. When emission is on and the Enable pin is set low, emission is shut off.

Pin #	Signal	Description
C4	Enable logic input	Logic input that permits laser emission when 4 to 12 V is applied. If during emission the input is set low, emission is shut off. This control input is for personal safety and is designed with redundancy within the module.
C9	Amplitude+	Input used to connect the positive signal of the differential input used for amplitude modulation. (Not currently used.)
C10	Wavelength+	Input used to connect the positive signal of the differential input used for wavelength modulation.
A5, A6, B5, B6, C5, C6	GND	0 volt / ground
A7, A8, B7, B8, C7, C8	12V	12 volt supply voltage for the BASIK module.

D CONTROL Software

Installing CONTROL

Download the software from:

<https://www.nktphotonics.com/lasers-fibers/support/software-drivers/>

Follow the steps in [Procedure 9](#).

Procedure 9 Installing CONTROL

Action

- 1 On the PC, launch the installer package and then click the Run button.

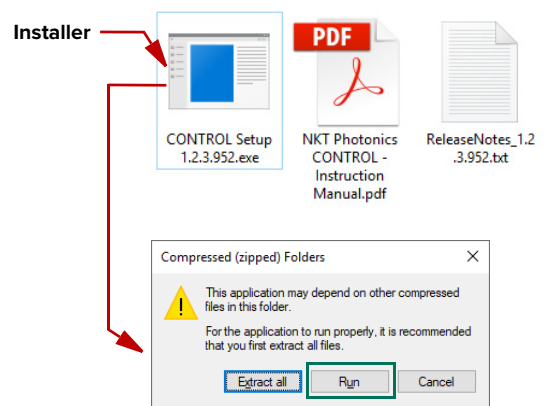

- 2 The installation wizard appears.
Click Next to continue.

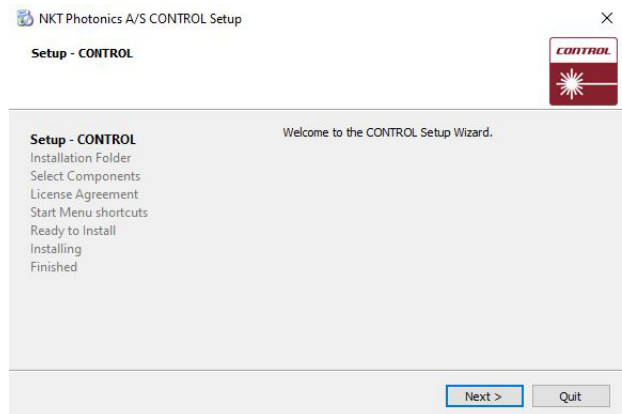

- 3 Accept to use the default installation directory or select another directory by clicking the *Browse* button.
Click *Next* to continue.

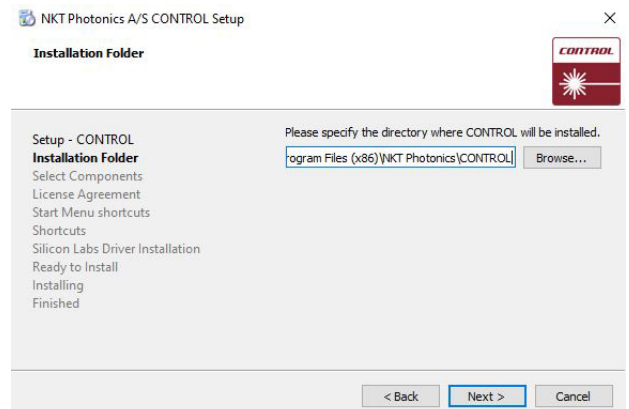

Action

- 4 Uncheck the components you do not require. By default, all components are installed.

Click *Next* to continue.

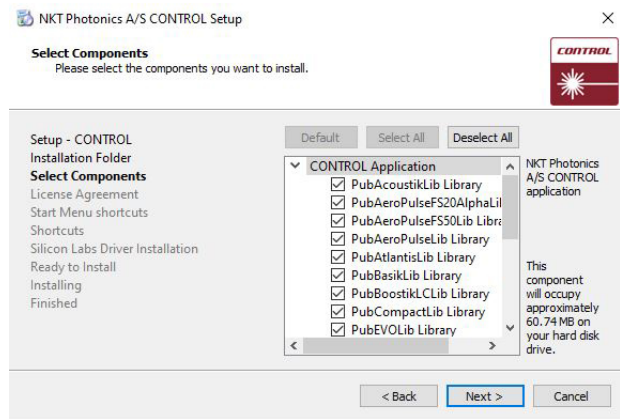

- 5 Read the End-User License Agreement, and check “I accept the license.” box.

Not checking the box ends the installation wizard.

Click *Next* to continue.

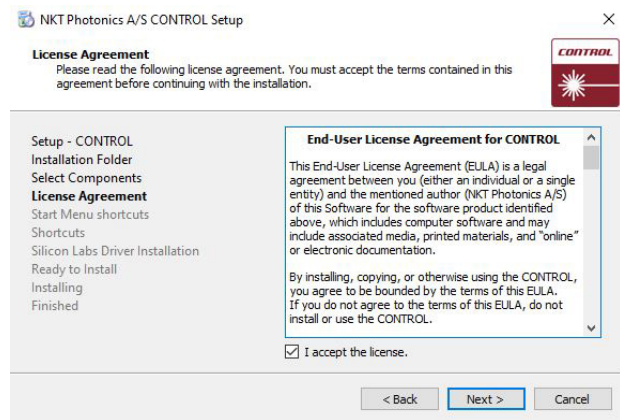

- 6 The wizard creates a start menu folder with program short-cuts.

Use the default name or enter a new name for the folder.

Click *Next* to continue.

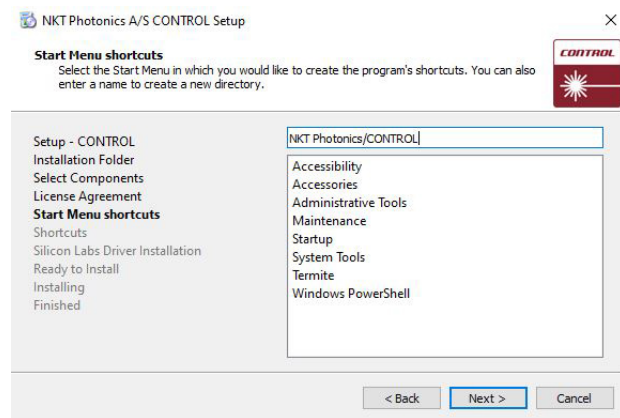

Action

7 Check the box to create a desktop shortcut to access Control.

Click *Next* to continue

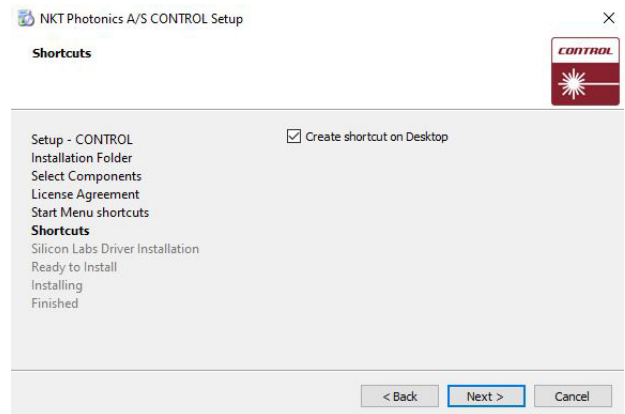

8 Check the 'Run the Silicon Labs CP10x driver installation' box and click *Next*.

Note: If you do not have the driver installed USB connectivity will fail.

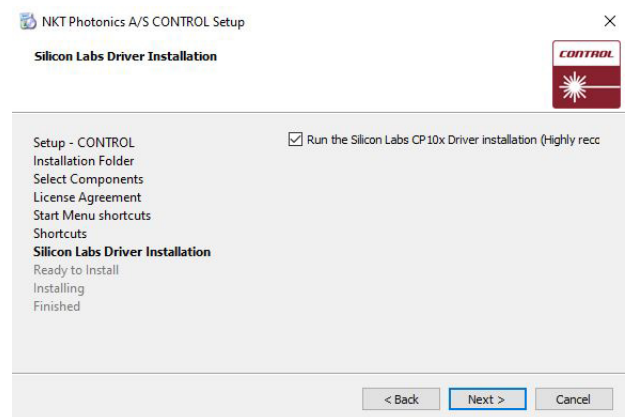

9 Click *Install* to install NKTP CONTROL software on your PC.

Click *Cancel* if you want to abort the installation..

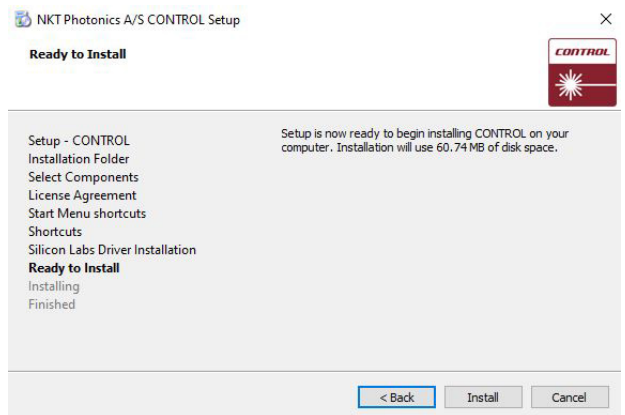

Action

10 The wizard displays a progress meter for the installation.

Note: a normal install should only take a few seconds.

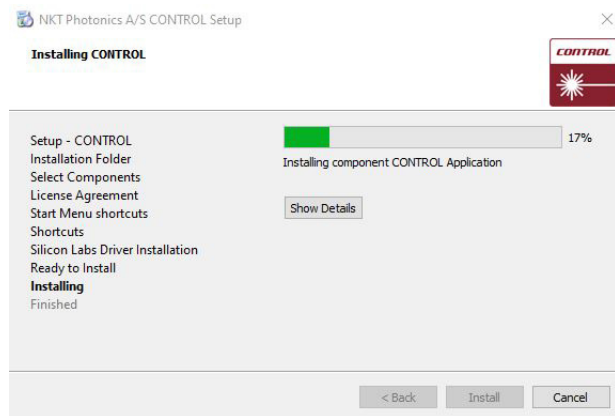

11 Click *Next* to install the UART drivers for the PC USB port.



12 The drivers are installed.

Note: Depending on your computer this occurs so fast you may not see this.

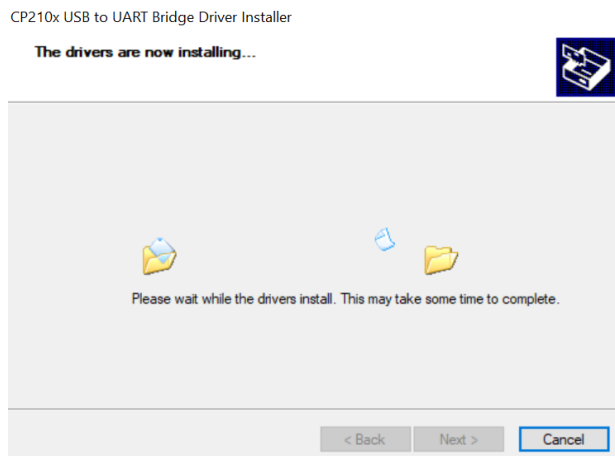

Action

13 The Silicon Labs drivers is installed successfully.

Click *Finish* to end the driver installation.

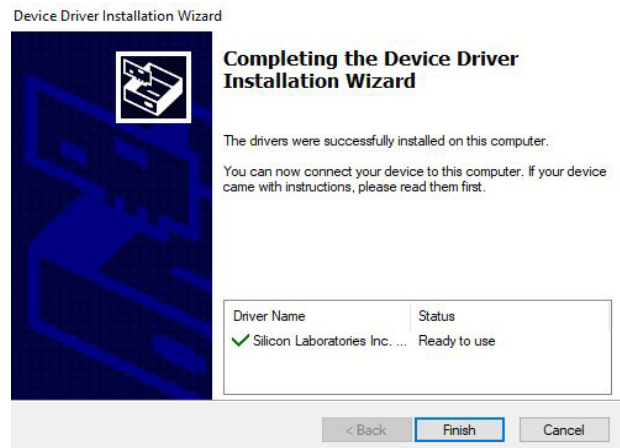

14 CONTROL is now installed.

Check the Run box to launch CONTROL when the *Finish* button is clicked.

Click *Finish* to end the installation wizard.

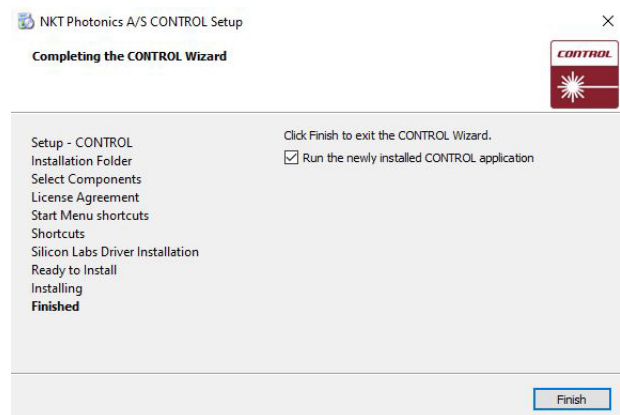

End of Procedure

E RS-485 adapter

If required, an RS-485 adapter kit is available for use with the laser. The adapter provides multiple functions:

- Input for DC power
- USB to RS-485 communication ports
- Interlock connection and jumper
- Status LEDs

If you need an adapter and its associated components contact NKT Photonics support, see [“Support contact details” on page 112](#).

Main adapter [Figure 74](#) depicts the adapter port interfaces that connect to both the PC and laser. The adapter’s main function is to connect and convert the laser’s RS-485 communication signals to serial USB and vice versa. The USB port can then be connected to either a management PC executing CONTROL or the SDK. The laser connects to the adapter using a 16 pin ribbon cable with a male DB-15 connector. For USB connectivity the adapter is equipped with a B-type USB port that typically connects to a PC using a standard Type A to Type B USB cable.

 **Note:** To connect a PC to the adapter, NKTP’s USB serial adapter software must be installed on the PC.

Power

The adapter also provides a two-pole power input socket to connect with an included external power supply. The connected DC supply powers the adapter and also provides power to the laser through the DB-15 connector and ribbon cable.

Interlock

To connect the laser’s interlock pins to a door switch, the adapter is equipped with a 3 pin connector that includes a jumper. With the jumper set over the center and outermost pin, the interlock is open and no emission is possible. Setting the jumper over the innermost and center pins, the interlock is closed and emission is possible.

 **Note:** Note the interlock circuit is closed when 5V is detected on pin 8 of the main electrical interface of the BASIK.

LEDs

The adapter includes three status LEDs that are described in [Table 21](#).

Table 21 RS-485 adapter status LEDs

LED	Condition	Description
Power	OFF	No Power Connector
	ON Green	12 VDC Power Connected
TX/RX	Flash RED	Adapter receives USB data (from PC)
	Flash Green	Adapter receives RS-485 data (from laser)
Emission	Off	No laser emission
	ON Red	Laser emission enabled

Figure 74 RS-485 adapter

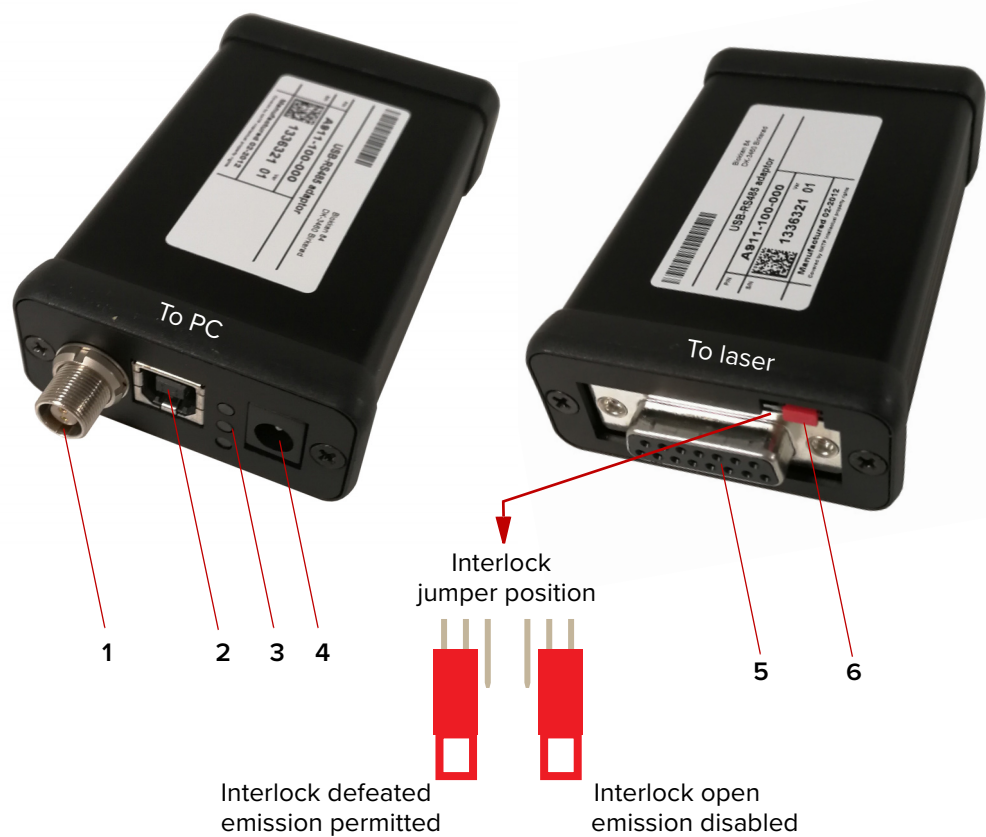

- | | |
|-------------------------|--|
| 1. Not used | 4. 12 VDC power input |
| 2. USB type B connector | 5. DB-15 laser interface – see Main electrical interface on page 113 |
| 3. Status LEDs | 6. Interlock connection and jumper |

F Configuration ID

BASIK modules are available as either Y10, C15, E15 or X15 variants (see [Table 1 on page 24](#)). The modules can be specified with various options that are indicated in the seven fields of the module configuration ID shown in [Figure 75](#). You can find a list of the standard configuration IDs in [Table 22](#).

Module Configuration ID

Figure 75 How to read the configuration ID

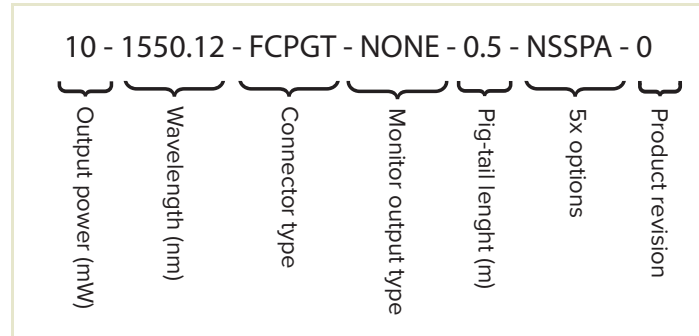

Table 22 Standard BASIK configuration IDs

Variant	Output Power (mW)	Wavelength (nm, vacuum)	Connector type ⁱ	Monitor output type ⁱⁱ	Pigtail Length (m)	VOA ⁱⁱⁱ	Linewidth ^{iv}	Piezov ^v	Enhanced Vibration Immunity ^{vi}	Polarization Maintaining ^{vii}	Product Revision
Y10	10	- ####.##	- FCPGT	FCPGT	- 1.5	- N	S	S	P	A	- 0
Y10	10	- ####.##	- FCPGT	FCPGT	- 1.5	- N	S	S	P	A	- 0
Y10	10	- ####.##	- FCPGT	FCPGT	- 1.5	- N	S	S	P	A	- 0
Y10	10	- ####.##	- FCPGT	NONE	- 0.5	- N	S	S	P	A	- 0
Y10	10	- ####.##	- FCPGT	NONE	- 0.5	- N	S	S	P	A	- 0
Y10	10	- ####.##	- FCPGT	NONE	- 0.5	- N	S	S	P	A	- 0
Y10	10	- ####.##	- FCPGT	FCPGT	- 1.5	- N	R	S	P	A	- 0
Y10	10	- ####.##	- FCPGT	FCPGT	- 1.5	- N	R	S	P	A	- 0
Y10	5	- ####.##	- FCPGT	FCPGT	- 1.5	- N	R	S	P	A	- 0
Y10	10	- ####.##	- FCPGT	NONE	- 0.5	- N	R	S	P	A	- 0
Y10	10	- ####.##	- FCPGT	NONE	- 0.5	- N	R	S	P	A	- 0
Y10	5	- ####.##	- FCPGT	NONE	- 0.5	- N	R	S	P	A	- 0
C15	10	- ####.##	- FCPGT	NONE	- 0.5	- N	S	N	N	A	- 0
C15	10	- ####.##	- FCPGT	NONE	- 0.5	- N	S	S	N	A	- 0
C15	10	- ####.##	- FCPGT	NONE	- 0.5	- N	S	N	P	A	- 0
C15	10	- ####.##	- FCPGT	FCPGT	- 1.5	- N	S	S	P	A	- 0
C15	10	- ####.##	- FCPGT	NONE	- 0.5	- N	S	S	P	A	- 0
E15	40	- ####.##	- FCBLK	NONE	- NA	- N	S	N	N	A	- 0
E15	40	- ####.##	- FCPGT	NONE	- 0.5	- N	S	N	N	A	- 0
E15	40	- ####.##	- FCPGT	FCPGT	- 1.5	- N	S	S	N	A	- 0
E15	40	- ####.##	- FCPGT	NONE	- 0.5	- N	S	S	N	A	- 0
E15	40	- ####.##	- FCBLK	NONE	- NA	- N	S	N	P	A	- 0
E15	40	- ####.##	- FCPGT	NONE	- 0.5	- N	S	N	P	A	- 0

Variant	Output Power (mW)	Wavelength (nm, vacuum)	Connector type ⁱ	Monitor output type ⁱⁱ	Pigtail Length (m)	VOA ⁱⁱⁱ	Linewidth ^{iv}	Piezov ^v	Polarization Maintaining ^{vi}	Enhanced Vibration Immunity ^{vii}	Product Revision
E15	40	- ####.##	- FCPGT	FCPGT	- 1.5	- N	S S	S	P	A	- 0
E15	40	- ####.##	- FCPGT	NONE	- 0.5	- N	S S	S	P	A	- 0
X15	30	- ####.##	- FCBLK	NONE	- 0.5	- N	S S	S	P	C	- 0
X15	30	- ####.##	- FCPGT	NONE	- 0.5	- N	S S	S	P	C	- 0
X15	22.5	- ####.##	- FCPGT	FCPGT	- 1.5	- Y	S S	S	P	A	- 0

- i. **FCPGT**=FC/APC pigtail (default), **FCBLK**=FC/APC bulkhead
SCPGT=SC/APC pigtail, **SCBLK**=SC/APC bulkhead
- ii. Same as in footnote "i" but also includes the option NONE.
- iii. **Y**=yes, includes a VOA, **N**=no, no VOA included
- iv. **S**=Standard, **R**=Reduced
- v. **S**=Standard (Piezo), **N**=Non-Piezo
- vi. **P**=Polarization Maintaining (PM), **N**=Non-PM - see
- vii. **A**=No, wide thermal tuning range, **C**=Yes, narrow thermal tuning range

Item:
Customer Revision:
NKTP Revision:
Release Date:

800-601-01
1.5
2.0
2022-03

